

ST. ELMO

Historic District Design Review Guidelines

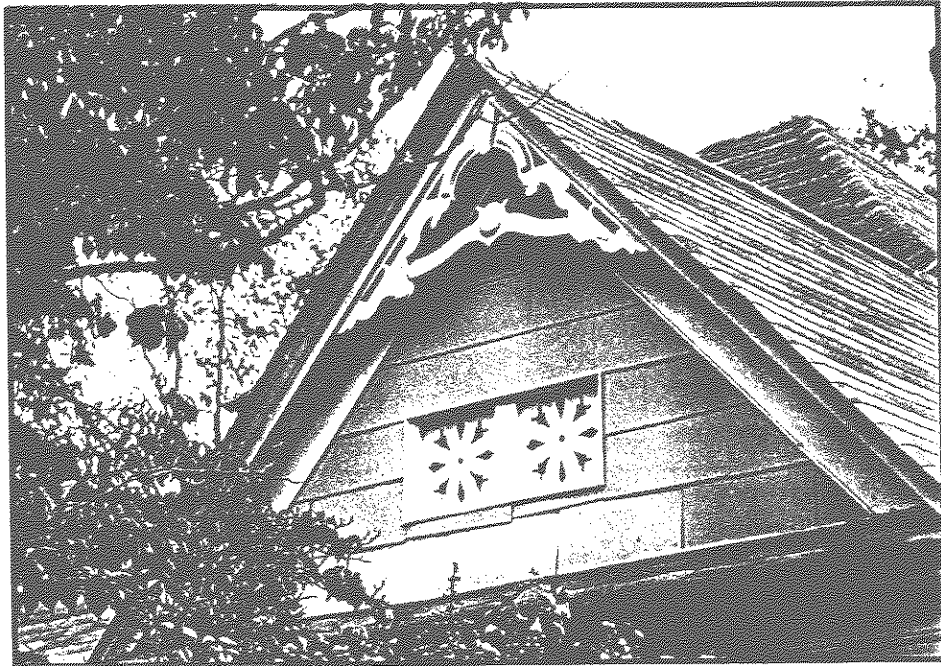

Prepared by:

Thomason & Associates

Chattanooga Historic Zoning Commission

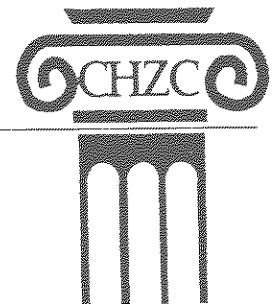

ST. ELMO HISTORIC DISTRICT
DESIGN REVIEW GUIDELINES
CHATTANOOGA, TENNESSEE

PREPARED FOR THE
CHATTANOOGA HISTORIC ZONING COMMISSION

THOMASON AND ASSOCIATES
PRESERVATION PLANNERS
NASHVILLE, TENNESSEE

MARCH, 1996

TABLE OF CONTENTS



INTRODUCTION	vi
Map of St. Elmo Neighborhood	vii
I. HISTORIC OVERVIEW	1
II. THE PURPOSE OF THIS MANUAL	4
III. THE APPLICATION PROCESS	8
IV. WHAT ARE THE BENEFITS OF DESIGN GUIDELINES?	10
V. BUILDING FORMS AND DISTRICT CHARACTER	13
A. House Forms - Queen Anne	19
B. House Forms - Gabled Ell	20
C. House Forms - Pyramid Square	21
D. House Forms - American Foursquare	22
E. House Forms - Craftsman/Bungalow	23
F. House Forms - Tudor Revival	24
G. House Forms - Ranch	25
H. Neighborhood Commercial Buildings	26
VI. DESIGN GUIDELINES - OVERALL APPROACH AND FORMAT	27
1. Additions	28
2. Architectural Details and Features	30
3. Awnings	32
4. Brickwork and Mortar	34
5. Chimneys	36
6. Decks	38
7. Demolition	39
8. Doors	40
9. Driveways and Paving	43
10. Fans	45
11. Fences	46

12. Fire Escapes	50
13. Foundations	51
14. Garbage Collectors	52
15. Gutters	52
16. Handicapped Access Ramps	53
17. Landscaping	55
18. Lighting	56
19. Masonry (Stone)	57
20. Mechanical Systems	60
21. Moving Buildings	61
22. New Construction	61
23. Paint and Paint Colors	69
24. Parking Areas	70
25. Porches, Porch Columns and Railings	71
26. Retaining Walls	76
27. Roofs	77
28. Satellite Dishes	79
29. Screens (screen doors, window screens, porch screening)	80
30. Security Doors and Windows	82
31. Shutters	83
32. Sidewalks and Walkways	85
33. Siding (lap siding, wall shingles)	86
34. Signs	92
35. Skylights	93
36. Solar Collectors	94
37. Staircases and Steps	95
38. Storm Windows and Doors	97
39. Swimming Pools	98
40. Wood	99
41. Windows	100
COMMERCIAL BUILDINGS	103
42. Storefronts	104
43. Entrances	105
44. Display Windows and Bulkheads	107
45. Windows	109
46. Cornices	111
47. Roofs	111
48. Architectural Features	112
49. Awnings	113
50. Lighting	114
51. Signs	115
52. Additions	117
53. New Commercial Buildings	118

APPENDICES

- A. Guideline Chart—Work Review Requirements
- B. Sample COA Application Form
- C. The Secretary's Standards for Rehabilitation
- D. Basic Maintenance Advice
- E. Definitions and Terms
- F. Suggested Bibliography

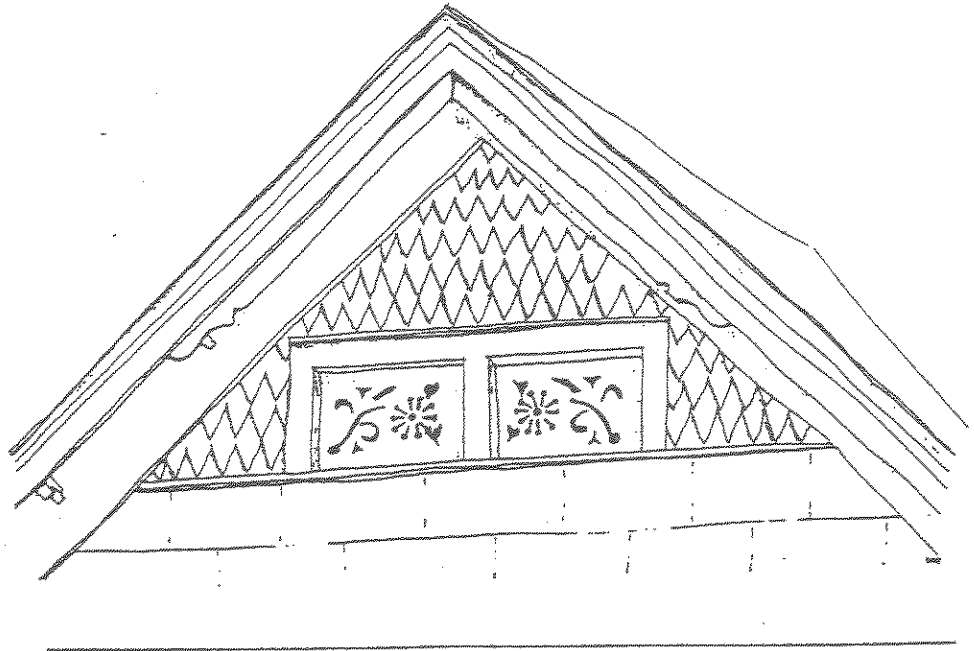

The St. Elmo Design Review Guideline Manual is dedicated to the memory of Roy Nelms. Roy Nelms was a St. Elmo resident who worked for many years to preserve and protect his neighborhood. He was an enthusiastic supporter of placing St. Elmo on the National Register of Historic Places and its designation as a local historic district. His life serves as an example of how one person's sense of community can make a difference.

ACKNOWLEDGEMENTS

Thanks are due to the many St. Elmo residents who provided their time to participate in the public meetings and planning process. In addition to the residents of St. Elmo, assistance in the preparation of this manual was provided by a number of persons and organizations. Thanks are due to the following:

St. Elmo Improvement League

Nora and Marvin Ernst
Gary Rudolph
Paul Worland
Frank Greene
Roy Nelms (Deceased)

Chattanooga-Hamilton County Regional Planning Commission and Riverfront-Downtown Planning and Design Center

Miranda R. Clements
Pamela Glaser

Chattanooga City Council Representative

David Distefano

Chattanooga Historic Zoning Commission

Theresa Place
Sally Betts
Frank Greene
Frank McDonald
Randall Soules
Gavin Townsend
Paul Worland
LaDell Peoples
Dale Mabee

The activity that is the subject of this publication has been financed in part with federal funds from the National Park Service, Department of the Interior. However, the contents and opinions do not necessarily reflect the views or policies of the Department of the Interior, nor does the mention of trade names of commercial products constitute endorsement or recommendation by the Department of the Interior.

INTRODUCTION

St. Elmo is an historic residential neighborhood located at the foot of Lookout Mountain in Chattanooga, Tennessee (1990 pop. 152,466). This neighborhood was developed in the 1880s and by the turn of the century it was home to hundreds of residents. Streetcar lines connected the neighborhood to downtown Chattanooga and it was a preferred residential area of the city during much of the early 20th century.

Like many inner city neighborhoods, the appearance and composition of St. Elmo changed in the years following World War II. Increased reliance on the automobile and the movement to the suburbs took their toll on older neighborhoods. Many descendants of the original St. Elmo families left the neighborhood and a number of S. Elmo's large dwellings were converted to apartments or allowed to deteriorate. Despite these changes the neighborhood still retained much of its architectural character into the 1970s. During this decade the nation's renewed commitment to historic preservation took hold benefiting neighborhoods such as St. Elmo.

By the early 1980s the sounds of hammers and saws were frequently heard as property owners rehabilitated their homes. The significance of St. Elmo was officially recognized when it was listed on the National Register of Historic Places in 1982. The nomination noted the hundreds of pre-1945 dwellings remaining in the neighborhood and its outstanding collection of architectural styles from this period. Over the next decade interest in protecting and maintaining the neighborhood's unique character grew stronger. The St. Elmo Improvement League played a major role in demonstrating historic preservation's role to improve the neighborhood's quality of life.

The efforts of the neighborhood were rewarded in 1992 when St. Elmo was designated a local historic district. As a local historic district, rehabilitation work, new construction, and demolition are reviewed by the city's Historic Zoning Commission. To assist in the Commission's review process and inform property owners, a booklet of guidelines for St. Elmo was published. While providing good general information concerning appropriate work in the neighborhood, the St. Elmo Improvement League and property owners felt more specific criteria was needed. The St. Elmo Design Review Guideline Manual is the response to this request and includes detailed information regarding building rehabilitation and guidelines for new construction.

By and large, St. Elmo property owners want to do the right thing with their buildings. They want to maintain or enhance the appearance of their property, keep up property values, and improve the liveability of the neighborhood. Design guidelines help property owners understand the value and methods to preserve and maintain the essential character of their property.

In the final analysis, historic zoning and design guidelines are about community. When we live in a locally zoned district we give up our ability to tear down our property or remodel it as we please. What we get in return is knowing that by following certain guidelines our investment in our property will be protected and the entire neighborhood improved. It's a trade off and not everyone agrees with this idea. But most residents understand that without historic zoning, St. Elmo's appearance in ten or twenty years could be pretty uncertain. With historic zoning there is a clear commitment, purpose, and blueprint as to how the neighborhood will age gracefully into the 21st century.

St. Elmo

Local Historic
District Boundaries

Designated by
Chattanooga City Council
May 26, 1992

*Chickamauga - Chattanooga
National Military Park*

Incline Railway

Forrest Hills Cemetery



NORTH

Prepared by

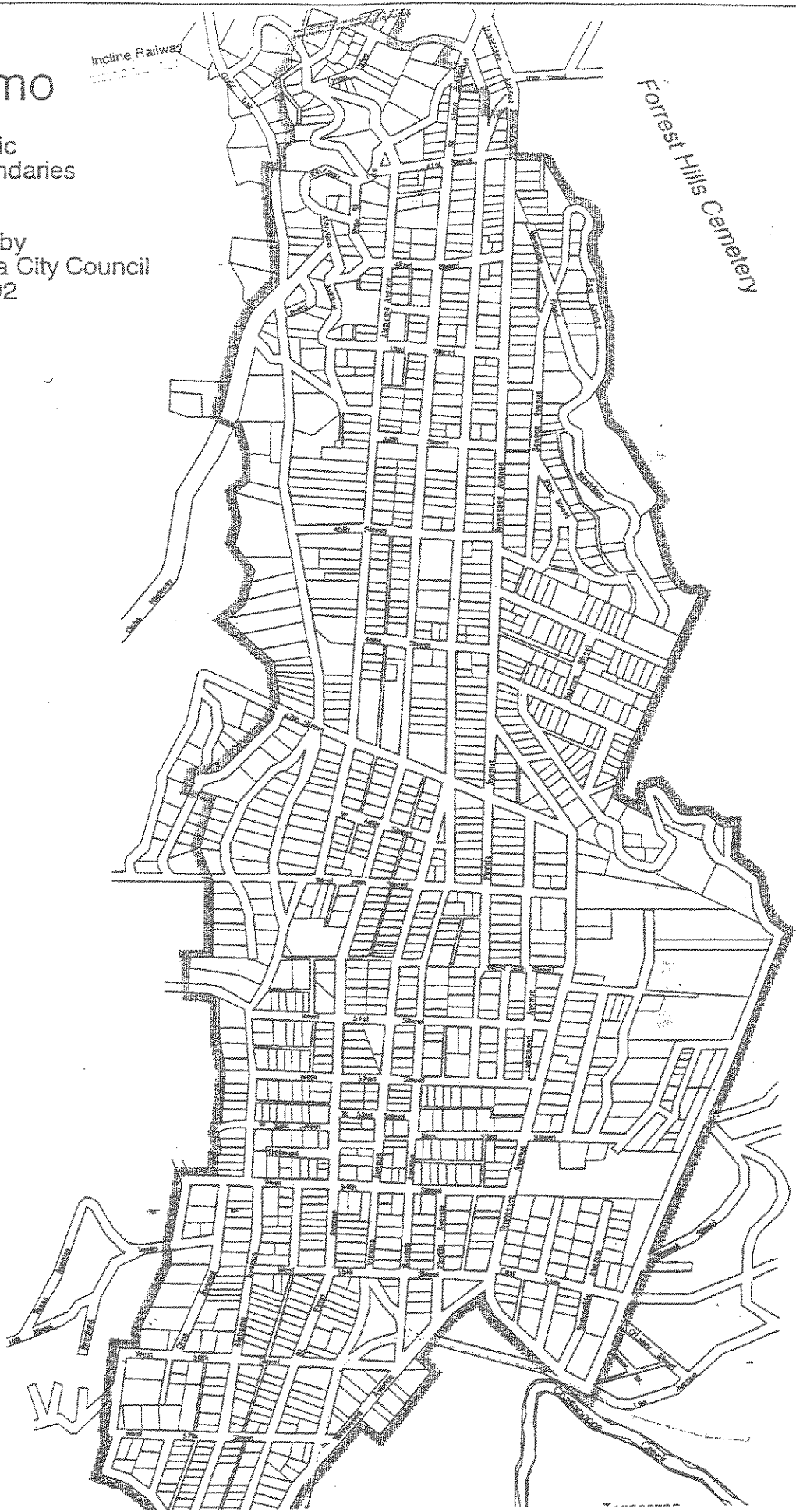

I. HISTORIC OVERVIEW

St. Elmo was developed in the late 19th century as Chattanooga expanded to the south, east, and north. During the 1880s a real estate boom took place in the city and many areas were bought and sold on speculation. St. Elmo was founded by Abraham Malone Johnson, a developer and businessman. Johnson was active in the formation of the city's water company, the Chattanooga Medicine Company, and Coca-Cola bottling. In addition to St. Elmo, he was one of the founders of nearby Forest Hills Cemetery.

Johnson began laying out and platting the area which was to become St. Elmo in 1885. This name came from the title of a fictitious novel by Augusta Evans Wilson that had its setting at the base of Lookout Mountain. Johnson had purchased this property following the Civil War when it consisted of farmland and woodlands. Johnson constructed a showplace residence on Alabama Avenue of brick and stone (now demolished).

The Chattanooga-St. Elmo Street Railroad Company was chartered in 1884 with financial support from Colonel A.M. Johnson, Z.C. Patten, and other prominent Chattanooga residents. This horse drawn street rail line was completed to St. Elmo in 1885. Electric streetcar lines began running out to St. Elmo by the early 1890s and this resulted in increased interest and sale of lots in the area. The electric streetcar lines provided a convenient and efficient mode of transportation to the downtown area while at the same time providing St. Elmo residents with the benefits of "country" living. The large lots and scenic vistas afforded by St. Elmo contrasted with the crowded commercial and industrial areas within the city.

In these years St. Elmo became a preferred residential area for the city's well-to-do and middle class. Early residents included Dr. Henry Berlin, Major L.L. Thomasson, and attorney Thomas H. Cooke. The neighborhood was the home to merchants, teachers, physicians, and business managers. At the east end of St. Elmo, workers' cottages were also built in the area around the Chatterm company.

In March of 1888 the Lookout Mountain Railway Company began regular service on its incline which extended from St. Elmo Avenue to the top of Lookout Mountain. Lookout Mountain became an important tourism center during these years due to the construction of several large hotels and the establishment of the military park. This original "Incline No. 1" was made obsolete by the construction of a new incline, "Incline No. 2" in 1895. This grade was much steeper than the original incline and it proved to be quicker and more direct. The Railway Company constructed a station to serve the incline and a small commercial area developed adjacent to the station to serve visitors and residents.

The Chattanooga Medicine Company (Chatterm) was the largest business in the St. Elmo commercial area. This company was formed in 1879 and produced several popular products including the liver medicine "Black Draught". St. Elmo developer Abraham Johnson relocated the business to St. Elmo Avenue in 1889 where it occupied a large brick building. By 1910, this company occupied a large complex of two- and four-story brick buildings and employed over 350 workers.

By 1900, the population of Chattanooga was approximately 29,100. The expansion of streetcar lines out from the city limits resulted in a number of satellite villages including St. Elmo. In 1905, St. Elmo was incorporated and described as having "many large distinctive homes and well-kept yards". The St. Elmo School was constructed on land donated by Colonel Abraham Johnson and this frame building was later replaced by the present brick building constructed in 1906 at the corner of St. Elmo Avenue and W. 47th Street. The first Parent-Teacher Association in the area was founded at this school.

During the early 1900s St. Elmo continued to thrive with extensive residential construction and civic improvements. An \$80,000 sewer project was initiated in 1911 and all of the streets were paved by the 1920s. The population growth in the neighborhood resulted in a large addition to the original St. Elmo school in 1915. The 1917 Sanborn map of the St. Elmo neighborhood shows thriving commercial and residential development throughout the area. Residential development was concentrated along St. Elmo and Alabama Avenues. By 1917 most lots had been developed along these two streets between 40th and 49th Streets. Between 49th Street and 57th Street St. Elmo Avenue continued to boast dwellings on most lots, however, residential development was sparse along Alabama Avenue. Virginia, Tennessee, Florida, and Beulah Avenues were less developed with many vacant lots and open areas. In addition to the dwellings built in the neighborhood there were also a number of frame and brick corner commercial buildings.

Interspersed with the residential and commercial buildings were a number of churches and public buildings. These included the Methodist Episcopal Church at St. Elmo Avenue and E. 42nd Street and the Thankful Memorial Episcopal Church on Thankful Place. Further down St. Elmo Avenue was the St. Elmo Presbyterian Church at E. 44th Street and the St. Elmo Baptist Church at E. 45th Street. The Christian Church was built at St. Elmo Avenue and 48th Street, and the Union Church was built in the 4900 block of St. Elmo Avenue. The Thankful Memorial Chapel was named in honor of Thankful Whiteside Johnson, wife of St. Elmo developer Abraham Johnson. She died in 1890 and was buried in Forest Hills Cemetery.

In addition to the residential area, a series of one- and two-story frame and brick commercial buildings were located adjacent to the incline railway station. These businesses included drug stores, grocery stores, and a bakery. A one hundred car automobile garage was located adjacent to the incline station to serve those driving to and from the incline. A three-story brick building housing the Bee Dee Stock Medicine Company was located on the south side of St. Elmo Avenue and this building continues to stand. A two-story public school serving the area's African American residents was located on School Street (now demolished). The area's largest employer, the Chattanooga Medicine Company, continued to expand in these years and occupied a large plant on Church Street north of St. Elmo Avenue.

Residential and commercial development continued into the 1920s and many dwellings built in the popular Craftsman and Bungalow styles were erected. The 1920s were a prosperous period for the city and St. Elmo was annexed into Chattanooga on September 30, 1929. When annexed into the city, the population of St. Elmo was estimated at around 6,000.

With the onset of the Depression in the 1930s, most construction in St. Elmo ceased and home building continued to be on hold during World War II. During these years many of St. Elmo's dwellings were subdivided into apartments to meet the housing demands of these years. At the end of the war in 1945 most new construction in Chattanooga took place on the edges of the city.

Areas such as East Ridge and Brainerd were the site of extensive suburban developments and in the 1950s and 1960s many St. Elmo residents moved to these areas. In keeping with national trends, renewed interest in historic neighborhoods such as St. Elmo has resulted in extensive building rehabilitation and preservation. Once again, St. Elmo is viewed by many to be a preferred residential area of the city.

The Historic Zoning Office



Chattanooga
Historic
Zoning
Commission

For copies of Guidelines, Certificates of Appropriateness, Staff Approvals, Advice on Specific Projects and Historic Zoning Commission Meetings:

Planning & Design Studio, 1250 Market Street,
Suite 3010 - Phone: 423-668-2262



COA Application Process

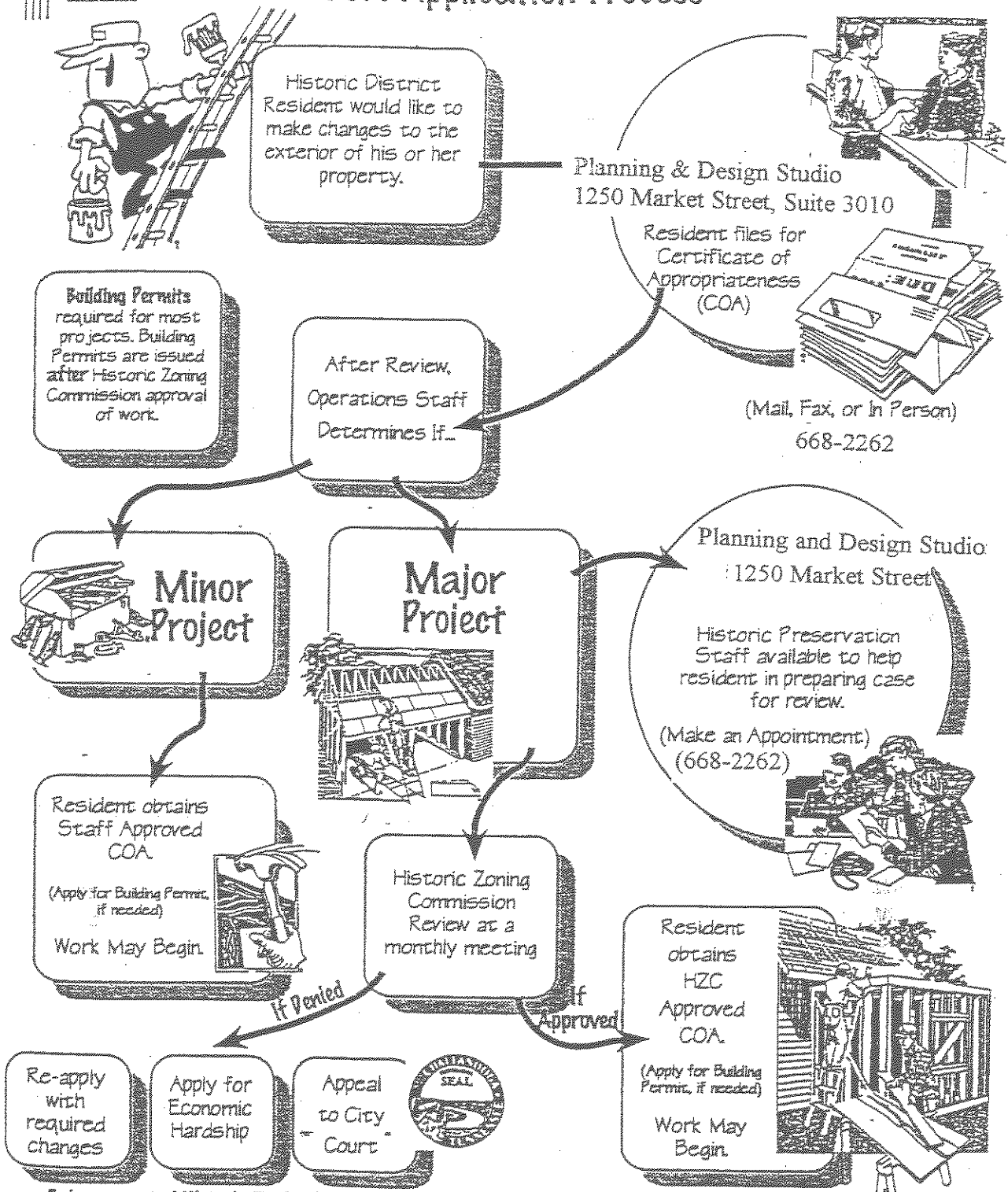

Enforcement of Historic Zoning is by the City of Chattanooga Building Inspection Department • 757-5105

The basics in the COA Application process.

The guidelines are organized alphabetically according to type of work. To use them, applicants should list each type of work they plan to do on a building or property and check the applicable guidelines. Exceptions to the guidelines can be made by the Commission if applicants demonstrate that the proposed work will be appropriate based on historical evidence and documentation in the context of the particular structure or similar property in the St. Elmo Historic District.

Guidance Available

To help owners or other applicants plan and design projects or improvements that will meet the design guidelines, the Commission's staff is available for free consultations. Contact the office of the Commission at the Planning & Design Studio, 1250 Market Street, Suite 3010, call 668-2262. You will be given an application form to complete (see Appendix). Some work can be reviewed and approved upon receipt of a completed application; other work will require review by the Commission.

Routine Maintenance

Phone approvals may be granted for items that are considered to be routine maintenance. Such items include painting, replacing roof shingles to match existing, replacing gutters to match existing, and minor repairs and maintenance to any part of a building when there is no change in appearance. The staff will mail the applicant a COA for phone approvals which must be displayed on the property while work is proceeding.

Remember to Follow Other Requirements and Coordinate Your Work

In addition to the Commission's design review, property owners also need to follow requirements set forth in the city's zoning ordinance and building codes. Much of St. Elmo is zoned R-2 which is a residential category allowing certain uses of buildings and limitations on new construction. There are also standard building codes which will need to be followed by property owners or contractors. The city's Building Inspector's office can provide information on overall zoning and building code requirements. There may also be properties such as churches or commercial buildings which need to meet provisions of the American Disability Act (ADA). These provisions outline methods to access buildings such as handicapped ramps. Again, questions about the ADA can also be answered by the Building Inspector's office (call 757-5105).

Your Work is Appreciated

The City of Chattanooga and the Historic Zoning Commission appreciate the efforts and cooperation of property owners and others in following the guidelines and preserving St. Elmo—a very special place to live or work and an important historic resource for the citizens of the city.

III APPLICATION PROCESS

STEP 1. Determine if Work Requires Approval

If you are planning to do work on a property located within the St. Elmo Historic District, check the chart in the appendix to see which types of work require approval (COA) from the Historic Zoning Commission (CHZC) and which types require a building permit from the Building Inspector's Office. If in doubt, call the CHZC at 668-2262.

Generally, a COA is required for the following:

- Any construction, alteration, demolition, or removal within St. Elmo which requires a building or demolition permit such as construction of any additions to buildings, demolishing buildings, or moving buildings;
- Construction, alteration, demolition, or removal of structure(s) or appurtenances, any of which affect the exterior architectural appearance of the property within the District, but not requiring a building permit such as fences, gazebos, steps, etc.

A COA is not required for routine maintenance, exterior paint colors, landscape plantings, or interior changes.

STEP 2. Obtain a COA.

Complete and submit an application form (available from the Planning & Design Studio Office, 1250 Market Street, Suite 3010, 668-2262.

Application Requirements:

For existing buildings—

- A. An accurate sketch, photograph, or drawing of each elevation where changes are proposed, showing existing appearances and proposed changes; and
- B. A description of materials to be used and an overall scheme, including but not limited to foundation, walls, trim, windows, doors, roof, chimneys, and any other exterior surface or detail.

For new construction—

- A. An accurate drawing of all elevations showing proposed appearance and its relationship to adjacent and nearby buildings; and
- B. A description of materials to be used including all surfaces and details.

- ☞ The Commission staff will meet with you to discuss your project, answer questions, and advise you on whether or not your plans meet the design guidelines. If there is a conflict between your plans and the guidelines, the staff can offer advice on how to modify them to meet the guidelines.

If the work requires review by the Commission, the application will be scheduled for the next regular meeting of the Commission. Regular meetings are on the **third Thursday of each month** at 5:30 p.m. in the Planning and Design Studio, 1250 Market Street, Suite 3010 (668-2262).

- ☞ Upon approval, the staff issues the COA which includes a list of approved work.
- ☞ Appeals of Commission decisions may be made to the Hamilton County Chancery Court.
- ☞ If a COA has been denied to a property owner or if the property owner feels that the requirements are unsatisfactory, he or she may work with the CHZC and staff to amend a project so that it meets the guidelines. The CHZC and the staff are available as a resource to residents for advice on appropriate designs and available products. The St. Elmo Improvement League is also available to act as a liaison between the property owner and the CHZC.

3. Obtain a Building Permit

Building permits (if required) are available at the Building Inspector's (757-5105).

4. Begin Work

Remember: If your plans change while work is in progress, contact the Commission staff (668-2262) **BEFORE** undertaking a change or deviation from the COA. Work undertaken contrary to original approval in a COA or beyond the scope of the COA requires approval from the Commission or staff. The St. Elmo Historic District is monitored on a regular basis by the Commission staff. If a violation is discovered or reported to the staff, the following steps may be taken:

- The Building Inspector's Office may issue a Stop Work Order. At this point the property owner should obtain COA approval of the work from the Commission. If the work does not meet the design guidelines, the Commission may require that the work be redone.
- If the property owner does not respond to the Stop Work Order, the Building Inspector's Office may issue a citation for violating the ordinance. This will outline deadlines for responding. If the property owner still does not respond, the Building Inspector's Office may issue a citation to appear in court.

Without approval, the work will be considered a violation (a misdemeanor with fines up to \$500, with each day the violation continues constituting a separate offense).

IV. WHAT ARE THE BENEFITS OF DESIGN GUIDELINES?

GUIDELINES BENEFIT CHATTANOOGA

- > Improvements in St. Elmo are part of overall city-wide efforts to promote and improve its older neighborhoods. Chattanooga has recognized that revitalizing its historic areas increases its tax base, assists in economic development, and is fiscally responsible. Design guidelines provide practical assistance and direction to assure that improvements are compatible with the goals and desires of property owners, the neighborhood, and the city.
- > The incremental value of neighborhood rehabilitation efforts can be just as important to economic development as more visible projects such as the Aquarium and Warehouse Row. Because neighborhood improvements are completed gradually, their cumulative effect is often not as well recognized. The overall impact of revitalization efforts can be measured not only in rising property values but also in its contribution to the city's quality of life and ability to attract new businesses.
- > The revitalization of older neighborhoods such as St. Elmo is of greater economic benefit to a city than is the continuation of suburban sprawl. Low-density development is much more costly than is compact development due to the required expenditure on roads, sewers, and public services. St. Elmo already possesses an efficient infrastructure with its existing sidewalks, streets, sewer lines, and street lights. Through appropriate rehabilitation of existing buildings and compatible new construction, St. Elmo contributes to a fiscally responsible approach to Chattanooga's urban renewal.
- > Historic architecture attracts visitors to cities. Part of the attraction of the Chattanooga Choo Choo, Warehouse Row, and Read House is their historic buildings. Heritage tourism, or tourism which focuses on historic areas and sites, is one of the rapidly growing segments of the tourism industry. The quality and quantity of the historic architecture in the St. Elmo neighborhood provides opportunities to enhance tourism in the city. Design guidelines encourage historic rehabilitation that is authentic and reinforces neighborhood character.

GUIDELINES BENEFIT ST. ELMO

- > St. Elmo is a unique neighborhood. It contains one of the largest and finest collections of early 20th century residential architecture in Tennessee. The neighborhood possesses a wide range of architectural styles, materials, and landscape elements set within the dramatic backdrop of Lookout Mountain. The intrinsic value of such an area can best be preserved and maintained through design review guidelines.
- > Design review is the only way to prevent demolition of significant buildings. St. Elmo's listing on the National Register of Historic Places does not provide any protection against demolition.

GUIDELINES BENEFIT THE PROPERTY OWNER

- > Our houses often represent our largest economic asset and we all want this asset to improve in value. Historic district designation and the use of design review guidelines helps to ensure that our investment in an historic area will be protected. Protected from inappropriate new construction, misguided remodeling, or demolition. Over time, property valuation in historic districts at worst stays the same, and in most cases, increases dramatically. No evidence exists to suggest that historic designation and the use of design guidelines lowers property values. Historic designation and design review benefits not only existing residents of the neighborhood but it often also attracts new buyers since they know their investment will be protected.

BUT WHAT ABOUT MY PROPERTY RIGHTS?

- > Design guidelines do not affect the use of your property or its interior. Property owners may remodel the interior as they choose and these changes are not reviewed as part of the design review process.
- > The design review process does not affect landscaping or paint colors. Landscaping and paint colors do not materially affect the fabric of the house and are left to the desires of the owner.
- > The design review process does not force property owners to make changes to their property. Design review only occurs when property owners propose changes to their property which may require a Building Permit or a Certificate of Appropriateness.
- > The design review process does not prohibit new construction or additions to historic buildings. Design review provides the framework for making new construction and additions as compatible as possible to the neighborhood.
- > Yes, when undertaking building rehabilitation, demolition, or new construction the Historic Zoning Commission will expect you to complete work according to the design guidelines. Through the guidelines the Commission protects the composite or overall economic value of the neighborhood including your own. Every building or parcel in the neighborhood is influenced by the actions of its neighbor and those around it. Every decision one property owner makes has an impact on the property value of another. Design guidelines provide a level playing field for all property owners because they apply to everyone in the district. This way all property owner's rights are protected from the adverse economic impact which could result from the actions of another.

WHAT ABOUT ECONOMIC HARDSHIP?

- > The CHZC can take into consideration economic hardship arguments of the applicant. In its determination, the CHZC would consider that by reason of the exceptional deterioration of the structure or by reason of the particular economics of the proposed project, the strict application of the Design Guidelines would result in peculiar and practical difficulties or undue economic hardship upon the owner to develop the property.

- > The CHZC would also consider whether the relief of the particular hardships would not establish substantial detriment to the public good or substantially impair the intent and purpose of the Historic Zoning Ordinance. The peculiar hardship would apply to the particular land or building regardless of the owner, and the peculiar hardship is not created as a result of an act upon the part of the applicant. For more information on Economic Hardship, contact the Commission staff at 266-5948.

HISTORIC BUILDINGS HAVE VALUE

- > Buildings in St. Elmo are known for their quality of construction and attention to detail. Many of these are approaching one hundred years of age and if properly maintained will last indefinitely. The life-span of dwellings and buildings constructed since World War II is more doubtful. Many buildings were constructed with life expectancies of only 30 to 40 years and their quality of construction may not justify their rehabilitation. St. Elmo's buildings may well have more enduring value than many built in recent decades.
- > The majority of the dwellings in the St. Elmo neighborhood are included as contributing buildings in the National Register Historic District. This makes income-producing properties eligible for the 20% historic tax credit if substantially rehabilitated. Income-producing would be buildings used for residential rental, offices, or commercial use. Since most of St. Elmo is zoned for residential use, rental residential is the use most qualifying for this tax credit.

The tax credit works this way - lets say I own an older house which I converted ten years ago into three apartments. If I exceed the adjusted basis of my property (adjusted basis is the purchase price, minus depreciation, plus capital improvements) with my rehabilitation expenditures I can take a 20% tax credit against my federal taxes. If the adjusted basis of my property is \$40,000 and I expend \$40,000 on its rehabilitation then I can take a tax credit of \$8,000 (20% of \$40,000). This \$8,000 is not a reduction in your taxable income but a direct federal tax credit to you. Sound like a good deal? You bet, and savvy property owners in St. Elmo can improve their property and their income at the same time.

Two scenarios come to mind if I want to improve my rental property. In the first I complete a substantial rehabilitation of my property and update my plumbing and wiring, replace the roof, and repair the exterior siding. I then have a more marketable rental property which will not require any substantial work for many years and a tax credit as well. In the second scenario I complete a substantial rehabilitation of my property, however, I remodel the interior in such a way as to make it easily convertible to single-family use or as a duplex. I can then take the tax credit and continue renting out the property for five years. At the end of five years I can convert the property to single-family use or sell as is. By waiting five years I avoid any recapture of the tax credit.

- > The majority of the buildings in the St. Elmo commercial area also qualify for a tax credit if substantially rehabilitated. Although not located within the St. Elmo National Register District, most buildings were constructed prior to 1936. For those buildings constructed prior to this date, a 10% tax credit is available for the rehabilitation of income-producing properties. These properties do not have to be listed on the National Register - they just have to be older than 1936.

Tennessee Avenues. By the early 1900s, construction had occurred along most blocks in the neighborhood and hundreds of Craftsman/Bungalow style dwellings were built in the 1910s and 1920s. Post-1950 dwellings are scattered throughout the district with large concentrations of these houses found only on a few streets or blocks. These include the 1600 blocks of W. 52nd and W. 53rd Streets, the 1400 block of W. 54th Street, the 5000 blocks of Florida and Beaulah Avenues, and the 4900 to 5300 blocks of Alabama Avenue.

In addition to the buildings, the character of St. Elmo is also reflected in its site and setting. The majority of lots in St. Elmo were originally 50' or 100' in width. Many of those originally laid out in 100' lots were later subdivided into two, 50' lots. This regular spacing gives the streetscape along most blocks a consistent rhythm or symmetry.

The majority of dwellings in the district have setbacks from 20' to 25' from the street. On some of the larger lots and those on steep slopes, the setbacks are generally somewhat greater - in the 30' to 50' range. Only a small number of dwellings have setbacks greater than 50' and these are located primarily on the steep slopes on the east side of Tennessee Avenue. The present R-2 zoning for the neighborhood maintains this tradition and characteristic with a minimum front yard setback of not less than 25'. In addition to dwellings, many original outbuildings such as sheds and automobile garages are located at the side or rear of the lots. These buildings are also important parts of the district's character.

The St. Elmo Historic District has a number of scattered vacant lots, however there are few large expanses of developable open space. The largest area of open space is on the east side of the 4600 block of Alabama Avenue. Within this block are large parking and playground areas associated with the adjacent vacant St. Elmo School. The St. Elmo School property offers a development opportunity in the neighborhood which could include rehabilitation of the school itself and new housing to the rear along Alabama Avenue.



Gabled Ell plan St. Elmo dwelling showing orientation and lot placement (4309 St. Elmo Avenue).

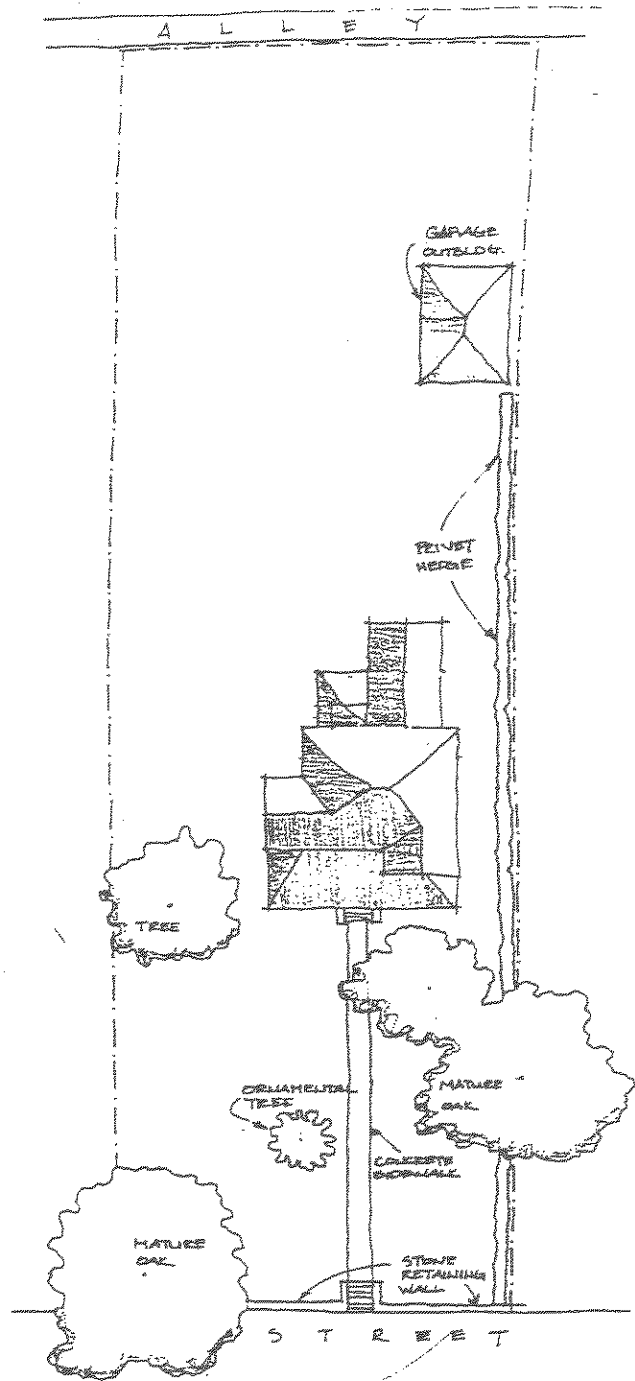
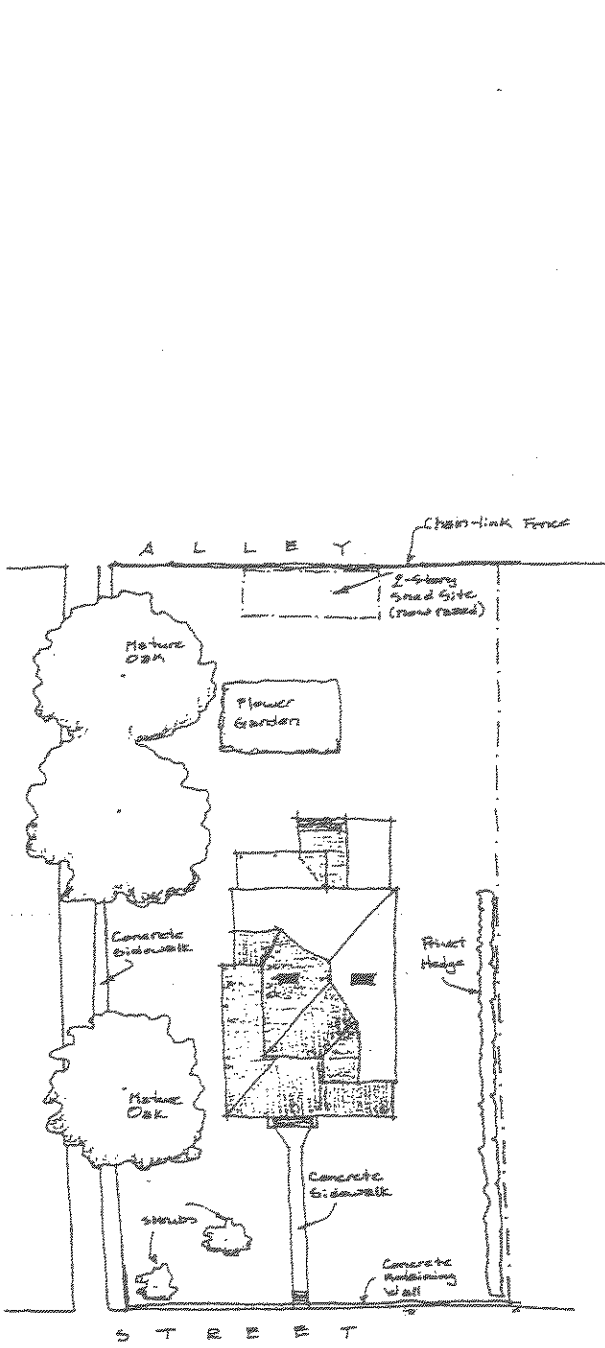

Representative lots showing typical lot size, building placement and landscape elements (4400 Tennessee Avenue and 4409 Alabama Avenue, respectively).

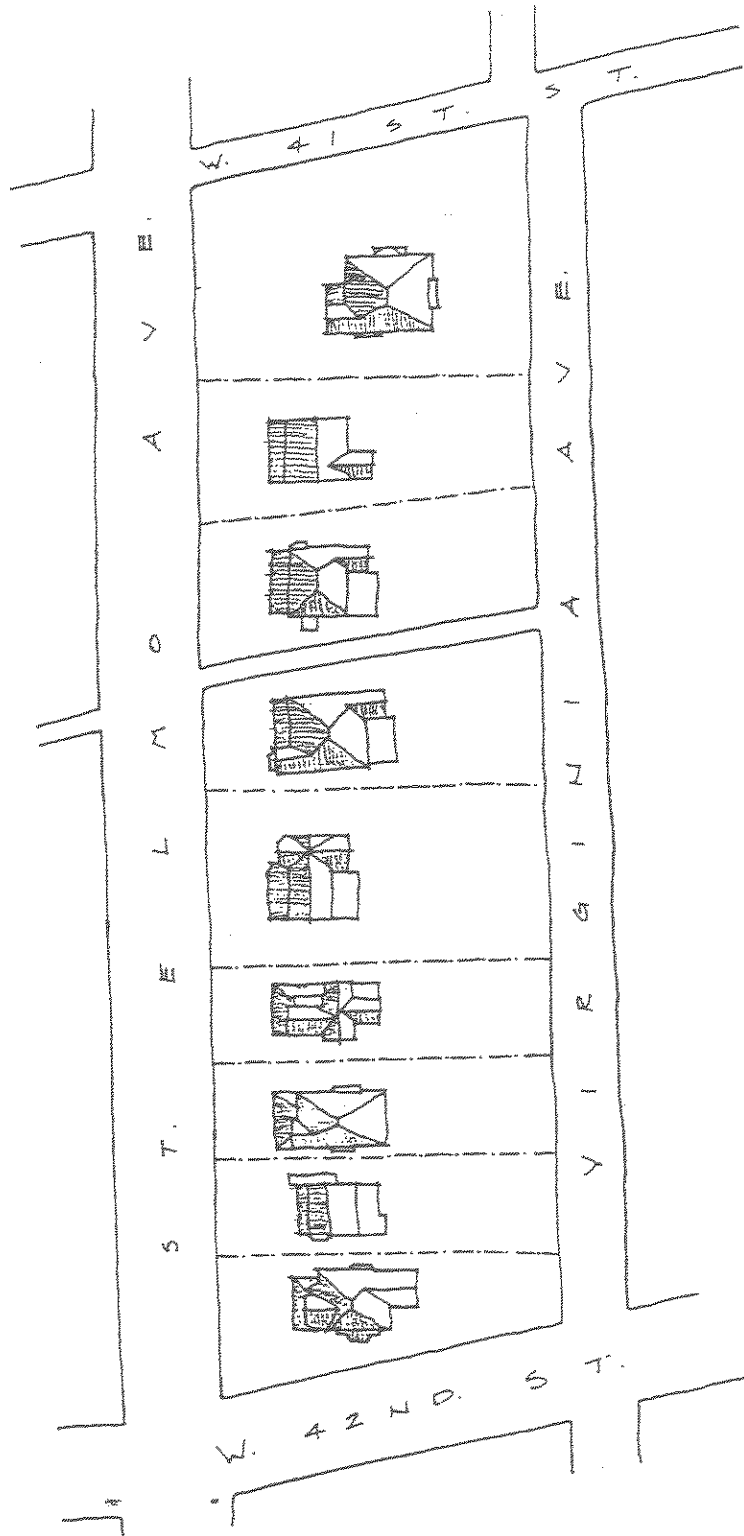

Representative block of dwellings on St. Elmo Avenue, showing uniform setbacks, lot placement and front porches.

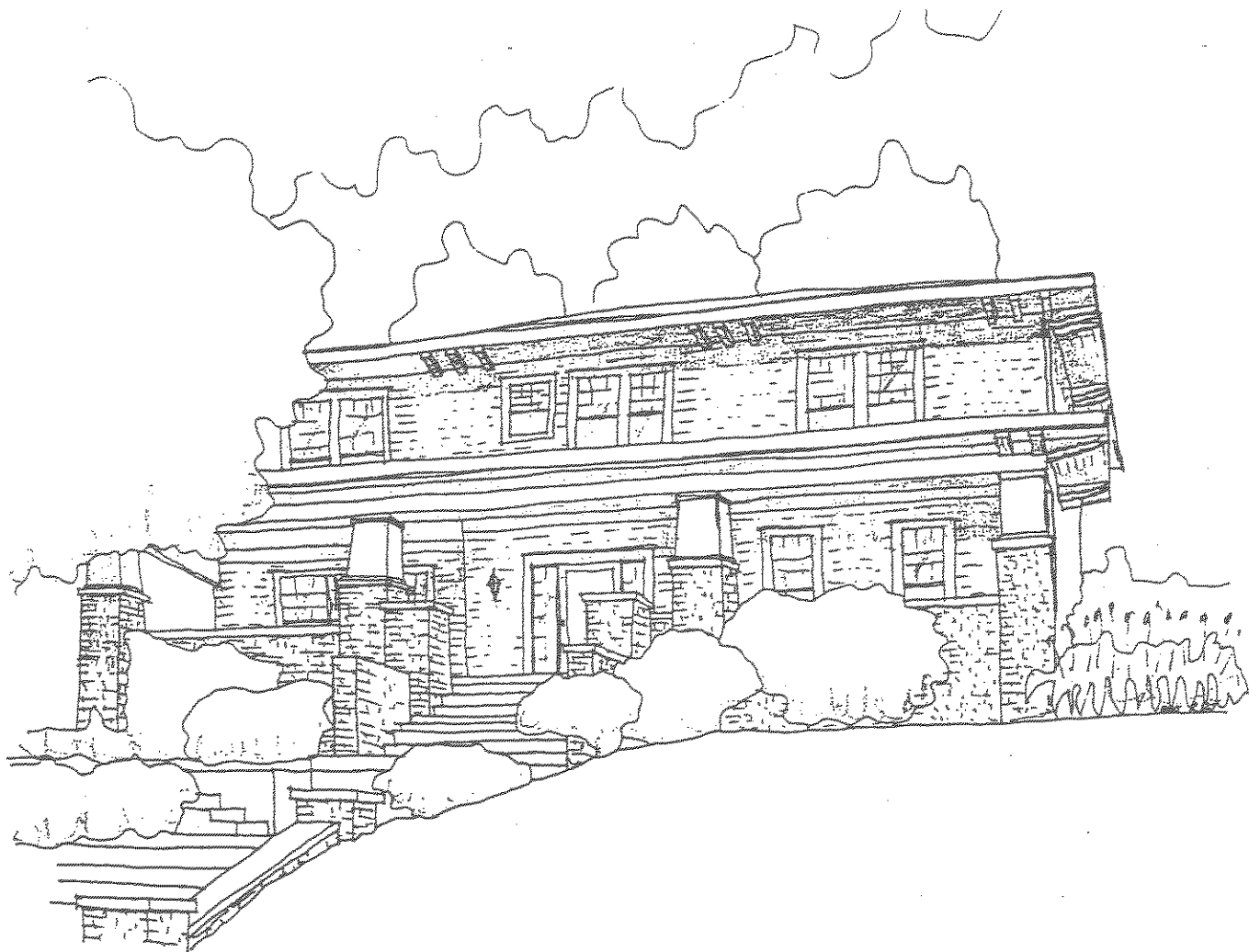

Large front porches and main entrances facing the street are typical in St. Elmo (4402 Tennessee Avenue).

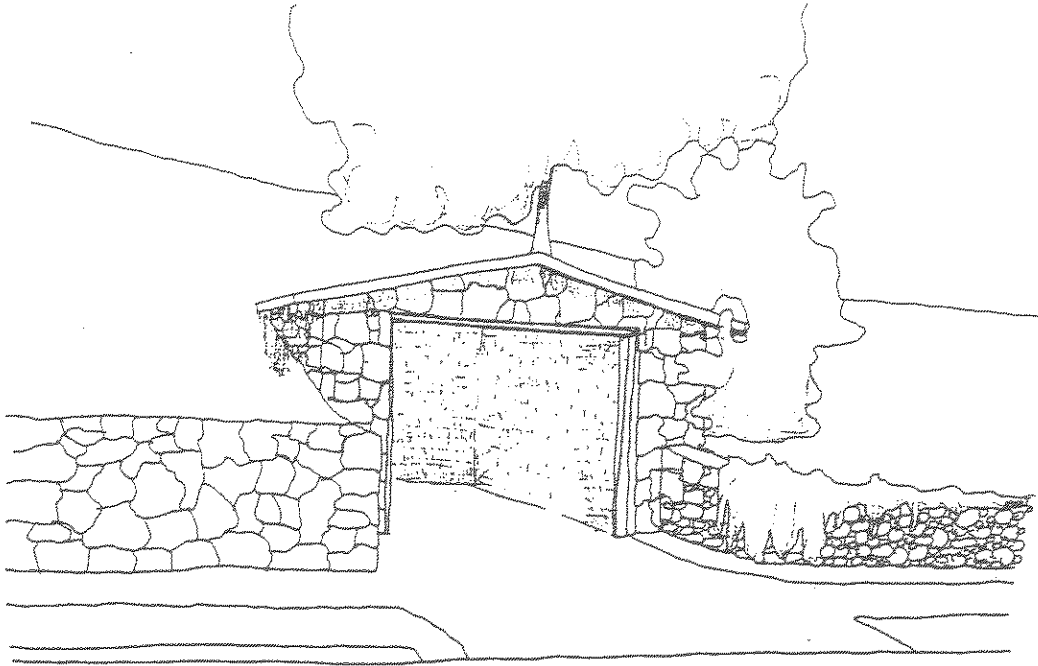

Stone garage at 4404 Tennessee Avenue.

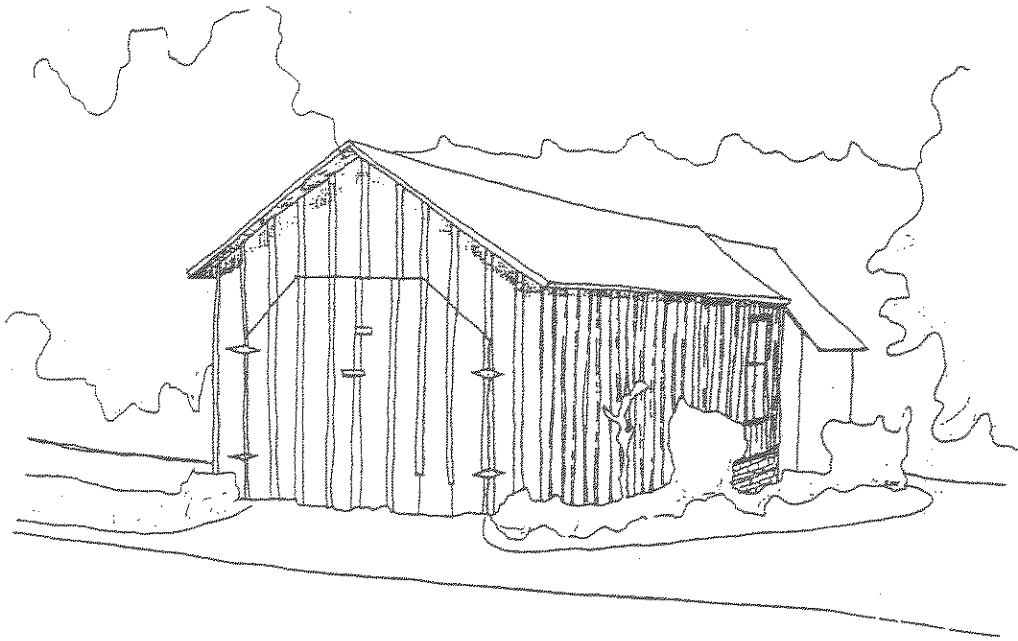

Frame garage at 4300 Alabama Avenue.

Historic garages are part of St. Elmo's character.

A. HOUSE FORMS - QUEEN ANNE, ca. 1880 - ca. 1910

The Queen Anne style was popularized in the late 19th century and featured an asymmetrical floor plan and extensive exterior detailing. This style is generally two-stories in height and often features corner towers, turrets, or projecting bays. Exterior wall surfaces are often varied with mixtures of brick, wood, stone, and wood shingles. Large wraparound porches with milled columns and balusters are usually present on the main facade. Windows are one-over-one sash or of small multi-light design. Roofs may have slate or metal standing seam surfaces. Brackets or decorative vergeboard are often found in the gables. Many fine examples of this style can be found along St. Elmo Avenue and adjacent streets.



Queen Anne style dwelling at 1606 West 43rd Street.

B. HOUSE FORMS - GABLED ELL, ca. 1880 - ca. 1915

Gabled Ell dwellings were popular throughout rural and urban areas of the Southeast at the turn of the century. This one- and two-story plan featured a gabled bay, or ell, projecting at a right angle from the rest of the house on the main facade. A rear shed wing or ell is also common to this house form. Gabled Ell dwellings are generally modest in terms of size but often display ornate millwork on porches and eaves. Porches often feature decorative milled columns, balusters, and vergeboard. Gabled Ell dwellings in St. Elmo generally display decorative vent windows or attached vergeboard in the projecting gables on the main facade.



A Gabled Ell dwelling at 4118 St. Elmo Avenue.

C. HOUSE FORMS - PYRAMID SQUARE, ca. 1900 - ca. 1930

Pyramid Square dwellings are early 20th century one-story dwellings constructed in simple rectangular or square shapes. They derive their name from their form in which the roof rises from the four corners of the house in a pyramidal or hipped shape. These dwellings are often simple in detailing with millwork generally confined to porch columns or at eaves. Front porches are common as are single-light glass and wood doors, and one-over-one sash windows.

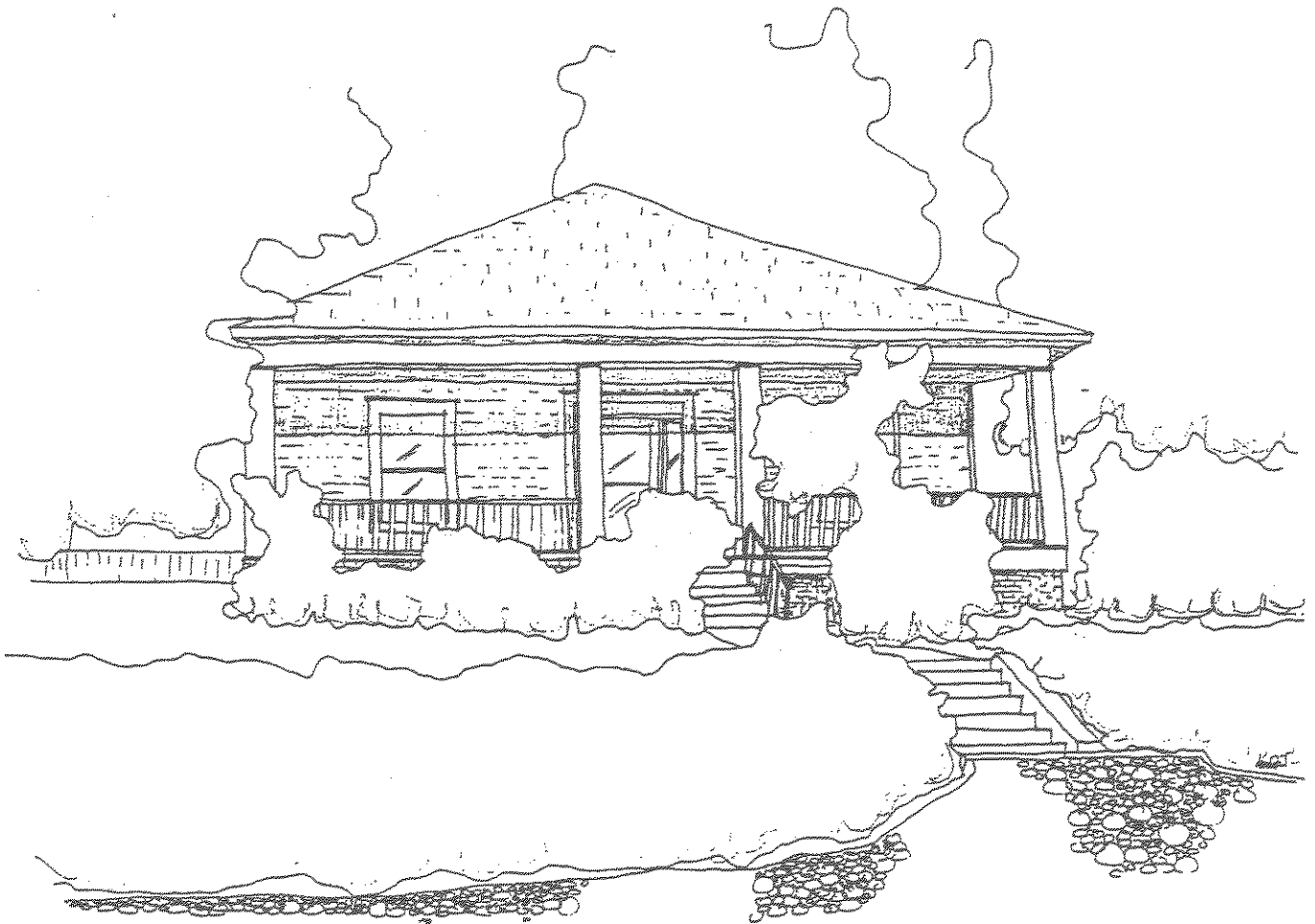

A typical Pyramid Square design at 4410 Tennessee Avenue.

D. HOUSE FORMS - AMERICAN FOURSQUARE

Another related version of the Colonial Revival style is the American Foursquare found throughout the neighborhood. American Foursquare designs feature rectangular plans with hipped roofs and one-story porches on the primary facade. Porches often have square or Tuscan columns and eaves often feature modillion blocks or brackets. The roofline on the primary facade often displays a hipped dormer window.

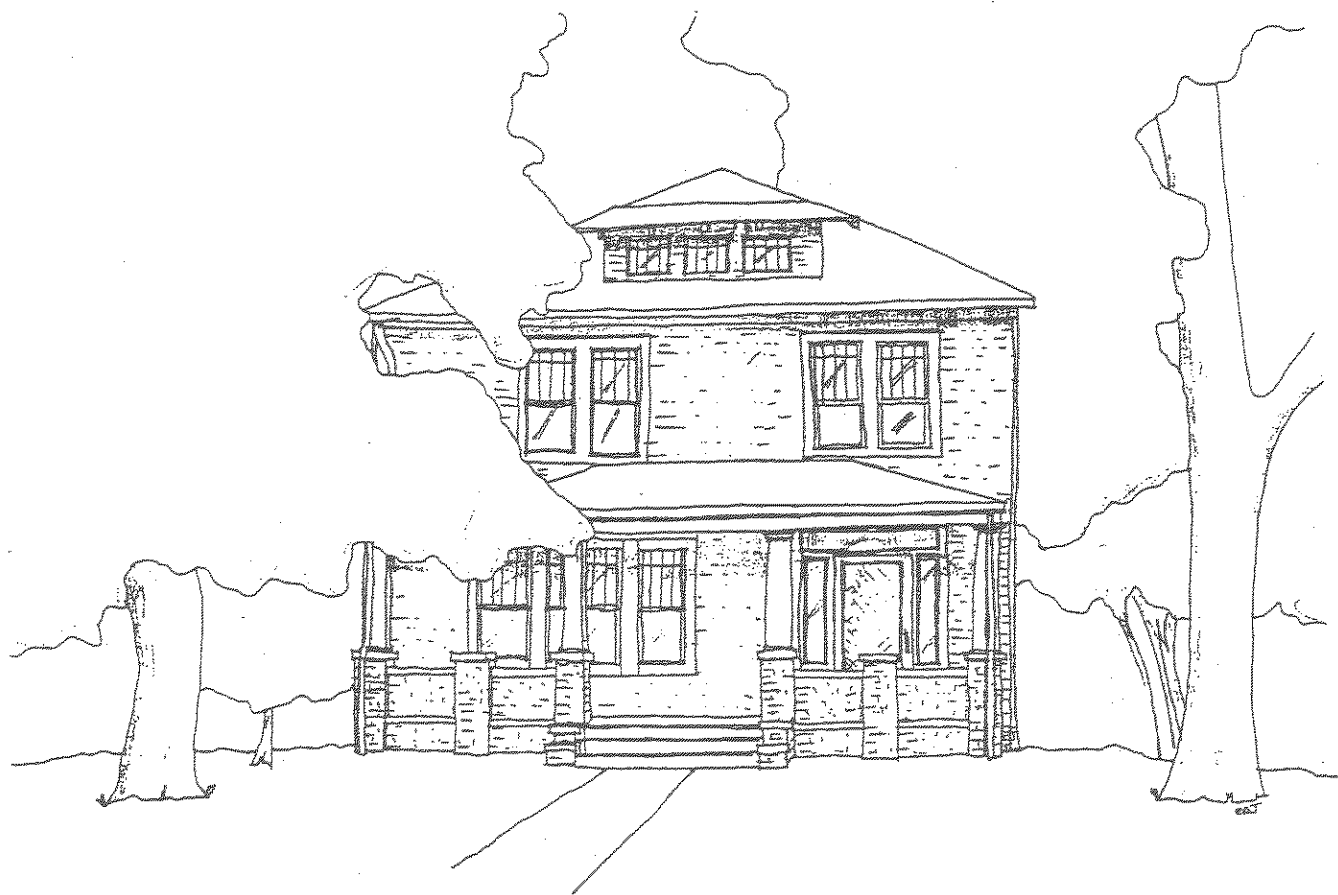

An American Foursquare dwelling at 4104 St. Elmo Avenue.

E. HOUSE FORMS - CRAFTSMAN/BUNGALOW STYLE, ca. 1910 - 1940

The Craftsman or Bungalow style was the most common architectural style in America during the early 20th century. The Craftsman style is characterized by square plans with low-pitch gable or hipped roofs, often with shed dormers. Windows are double hung-sash with three or more vertical lights in the top sash and a single-light bottom sash. Craftsman dwellings have large broad porches which usually extend across the front facade and are supported by tapered columns resting on stone, frame or brick piers. In contrast to the vertical emphasis in Victorian styles, Craftsman dwellings emphasized the horizontal, with wide windows and wide roof eaves. In many examples, rafter ends and knee braces are visible below the eaves. The popularity of the Craftsman style corresponded with the continued growth and development of St. Elmo and many dwellings reflect this style especially along Tennessee Avenue.

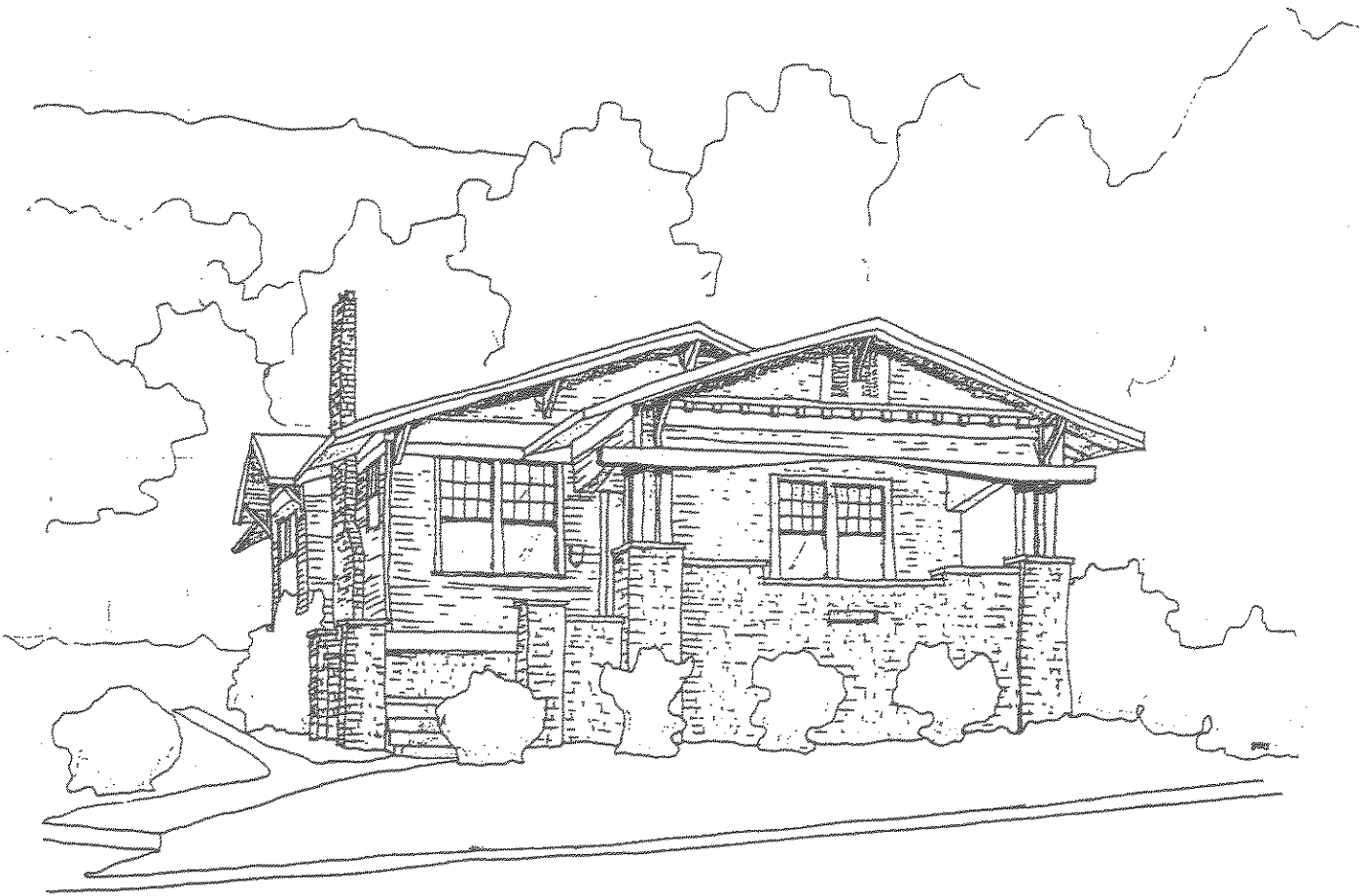

The dwelling at 4221 Alabama Avenue is a Craftsman style Bungalow.

F. HOUSE FORMS - TUDOR REVIVAL, ca. 1910 - 1940

Although less popular than Bungalows, the Tudor or English Revival style was also built in the St. Elmo neighborhood. These dwellings are based upon medieval house forms of England and were popular in America from 1915 to 1940. These house forms have high pitched gable roofs, multiple gables on the main facade, and are generally of brick and stucco construction. Doors are often set within rounded or Tudor arches while windows often have multiple lights in the upper and lower sashes. In gable fields stucco and wood are often combined to create the appearance of half-timbering.

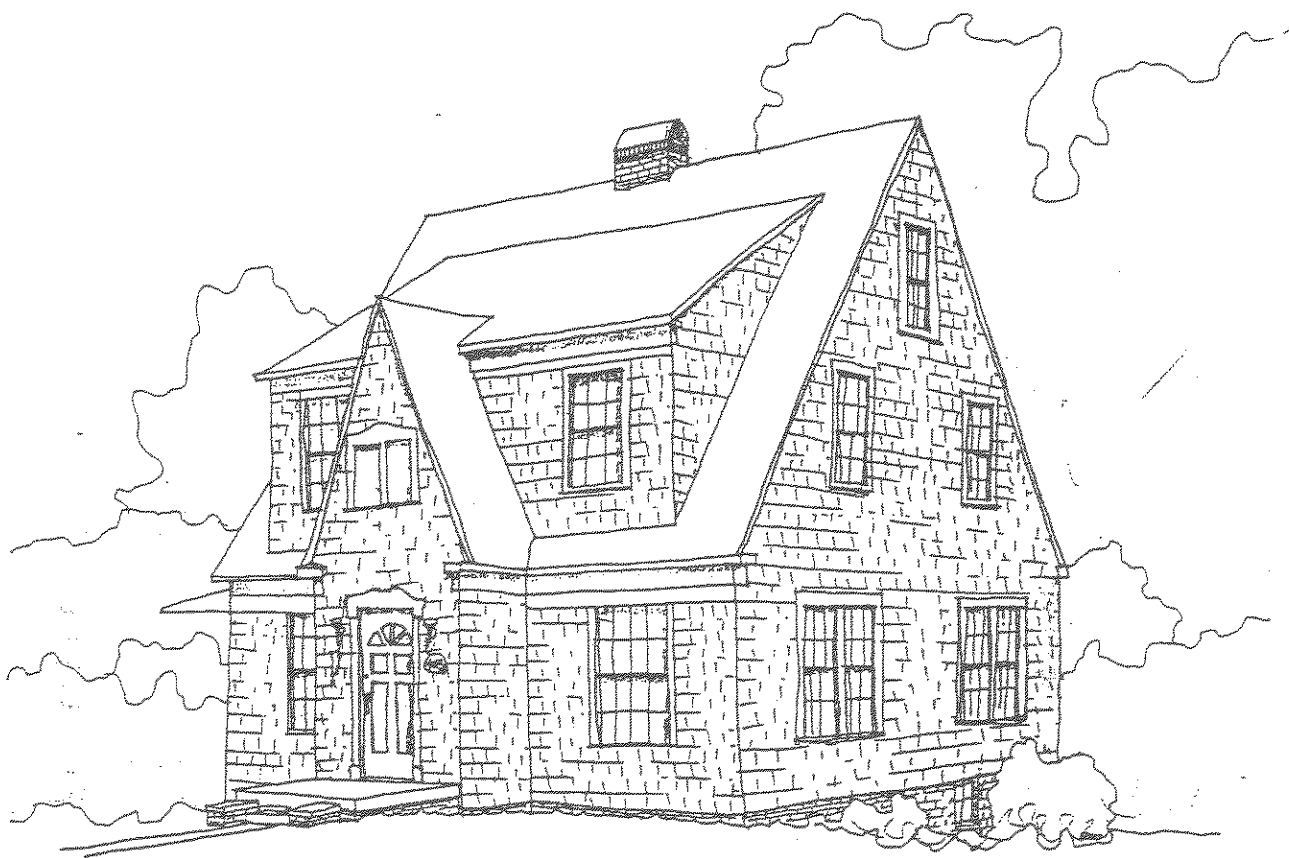

Tudor Revival influenced dwelling at 4118 Alabama Avenue.

G. HOUSE FORMS - RANCH

Following World War II, construction occurred on vacant lots throughout the neighborhood. Most dwellings built in St. Elmo in the late 1940s and 1950s were versions of the Ranch style which was popular throughout the country. The Ranch style reflects some elements of the Bungalow/Craftsman style in its low, horizontal appearance and slightly pitched gable roof forms. Projecting gabled bays on the front of the house are common. Detailing is usually minimal with plain eaves, rectangular windows, and metal or wood porch columns. Garages are often attached to the house. Porches and decks are more common at the rear than at the front of the house.

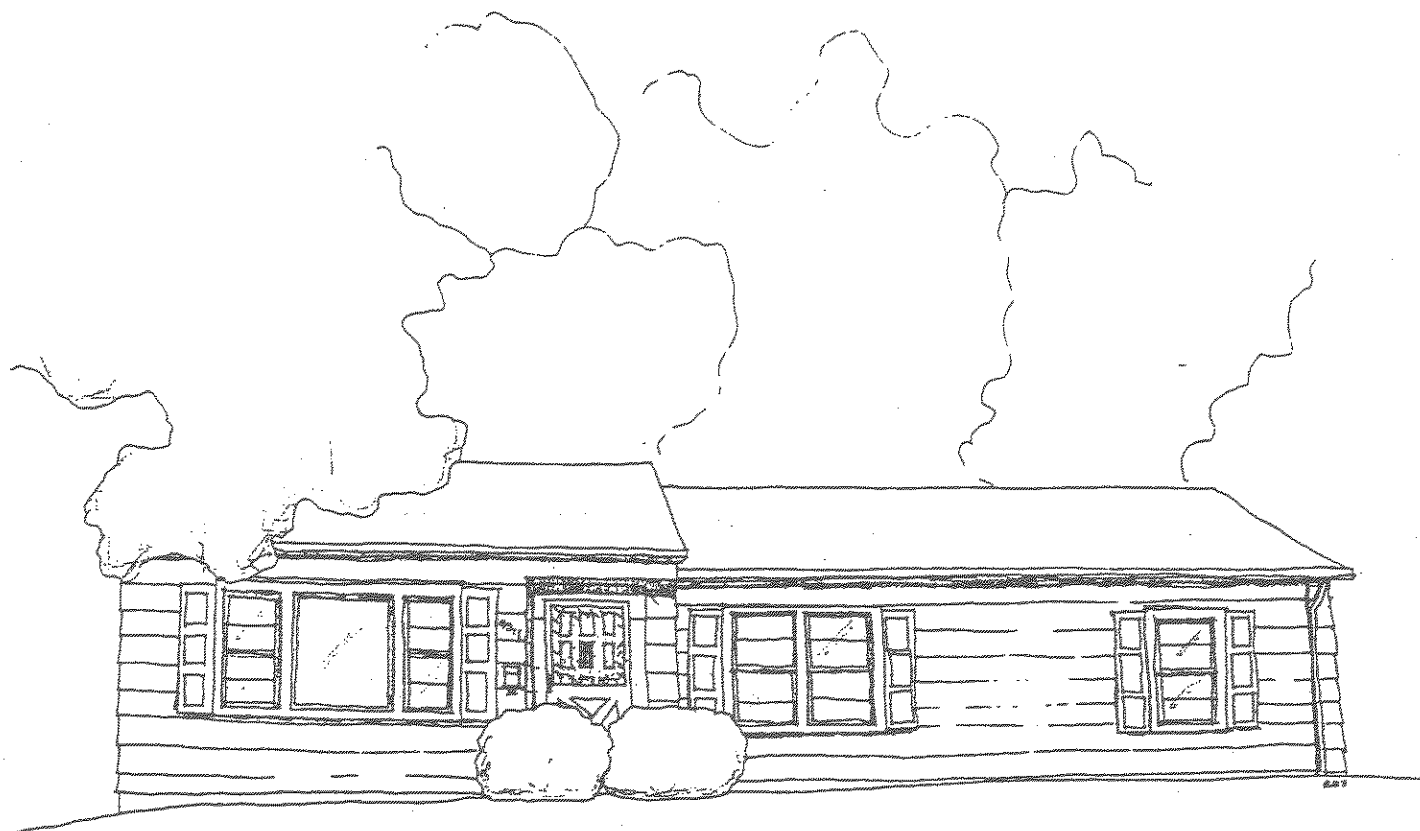

A Ranch style dwelling at 494 Guild Trace.

H. NEIGHBORHOOD COMMERCIAL BUILDINGS, ca. 1890 - ca. 1930

Primarily residential in character, St. Elmo also possesses a neighborhood commercial center and a scattered collection of neighborhood stores. The commercial center of St. Elmo evolved in the early 1900s to provide stores and services for the neighborhood. By 1915, this area contained a row of one- and two-story brick buildings housing clothing shops, drug stores, and grocery stores. Commercial buildings from this period share similarities in their composition and have separate storefronts and upper facades. Storefronts were designed to be as transparent as possible for merchandise display. Large display windows resting on short lower panels known as bulkheads, and often the front entrance had a large single light door. Upper facades of one-story buildings generally feature decorative brickwork and cornices. In addition to the decorative brickwork and cornices, two-story buildings feature symmetrically placed windows.



Neighborhood commercial building at 4900 St. Elmo Avenue (showing proposed rehabilitation).

VI. DESIGN REVIEW GUIDELINES

OVERALL APPROACH AND FORMAT

The main approach in design review guidelines is the emphasis on preservation over complete remodeling. This view is illustrated through the use of terms such as *repair*, *retain*, *maintain*, and *protect*. It is better to *repair* original materials rather than replace them; *retain* original neighborhood features such as stone retaining walls; *maintain* original porch columns; and *protect* the neighborhood from incompatible new construction.

This manual lists neighborhood guidelines in alphabetical order. Included is information on common rehabilitation questions, recommendations for maintaining the site and setting of the neighborhood and guidance for new construction. Illustrated descriptions of the architectural details in St. Elmo are included to familiarize property owners with typical features and characteristics. At the end of the guideline section are appendices which have a sample Certificate of Appropriateness, definitions of terms, suggested bibliography, and definitions of terms.

The design guidelines are primarily concerned with the fronts and readily visible sides of buildings. Most often the public views neighborhood buildings from the street or sidewalk. The fronts of buildings also contain the most defining features of the property such as porches, main entrances, and decorative details. The rears of buildings are usually reviewed with more flexibility since they are generally not readily visible due to the building's placement on the lot or screening by landscaping or fences. Construction at the rears of buildings is best when additional living space is required. Property owners are encouraged to refer to the guidelines when planning or designing new construction projects, planning exterior rehabilitations, and completing everyday maintenance.

The design guidelines apply to all properties within the St. Elmo Historic District regardless of age or architectural style. For non-historic buildings (properties which are less than fifty years of age or which have been substantially altered), the CHZC may apply the guidelines with more flexibility than for historic buildings. In reviewing work affecting non-historic buildings, the CHZC's approach is to maintain or enhance their relationship and compatibility with adjacent historic buildings and streetscapes.

The design guidelines are to be applied in a reasonable manner, taking into consideration economic and technical feasibility.

1. ADDITIONS (New Rooms)

Buildings must be able to adapt to the needs of each generation of occupants and this may include adding additional living space. In planning additions the best approach is to site additions where they will not be readily visible from the street, or where they will have the least effect on the building's overall form and plan. The rear of buildings are the best locations for the addition of rooms, wings, porches, or decks.

- A. should be located at the rear of buildings, not on the front or readily visible areas of the sides of buildings.
- B. should be secondary (smaller and simpler) than the original building in scale, design, and placement.
- C. should be of a compatible design in keeping with the original building's design, roof shape, materials, color, and location of window, door, and cornice heights, etc.
- D. should not imitate an earlier historic style or architectural period. For example, a Victorian-era Queen Anne style rear porch addition would not be appropriate for a 1920s Craftsman/Bungalow house.
- E. should appear distinguishable from the historic building, not an exact copy of it. Additions should be contemporary in design but compatible with the original building.
- F. should be built in a manner that avoids extensive removal or loss of historic materials and which does not damage or destroy the main architectural features of the building.
- G. should keep the exterior walls of the original building alone and use existing door and window openings for connecting the addition to the building.
- H. should not be made through framing or glassing in the front porch or a prominent side porch.

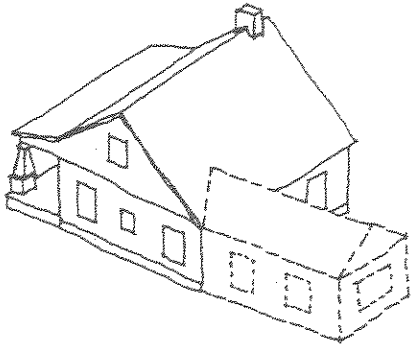

Yes

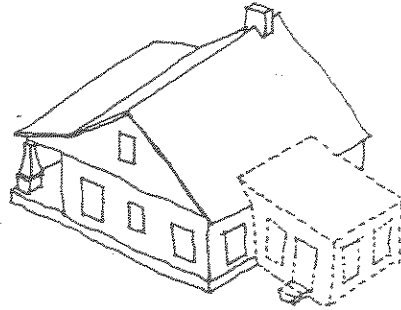

Yes

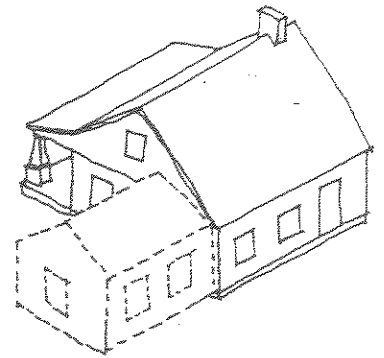

No

Additions should be made to the rear, not sides, of the house.

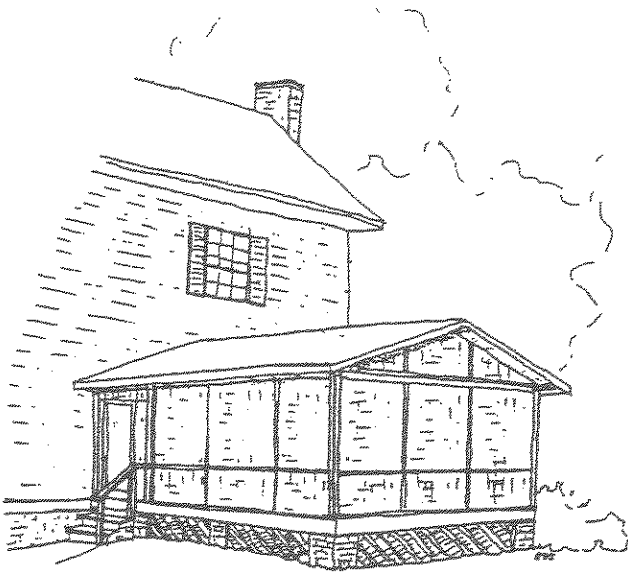

Acceptable rear addition variations.

2. ARCHITECTURAL DETAILS AND FEATURES

(Gingerbread, vergeboards, eaves, brackets, dentils, cornices, moldings, trimwork, shingles, columns, pilasters, balusters, or any decorative or character-defining features)

Architectural detailing is a major component in defining a building's character and style. Original architectural detailing should be preserved and maintained. If the details need to be replaced, the new materials should match the original as closely as possible.

- A. should not be removed or changed if original to the building.
- B. should not be added unless original and authentic to the building and accurately based on physical, pictorial, or historical evidence (not guesswork) in materials, scale, location, proportions, form, and detailing.
- C. should be repaired rather than replaced.
- D. should not be covered with vinyl or aluminum or other artificial siding.

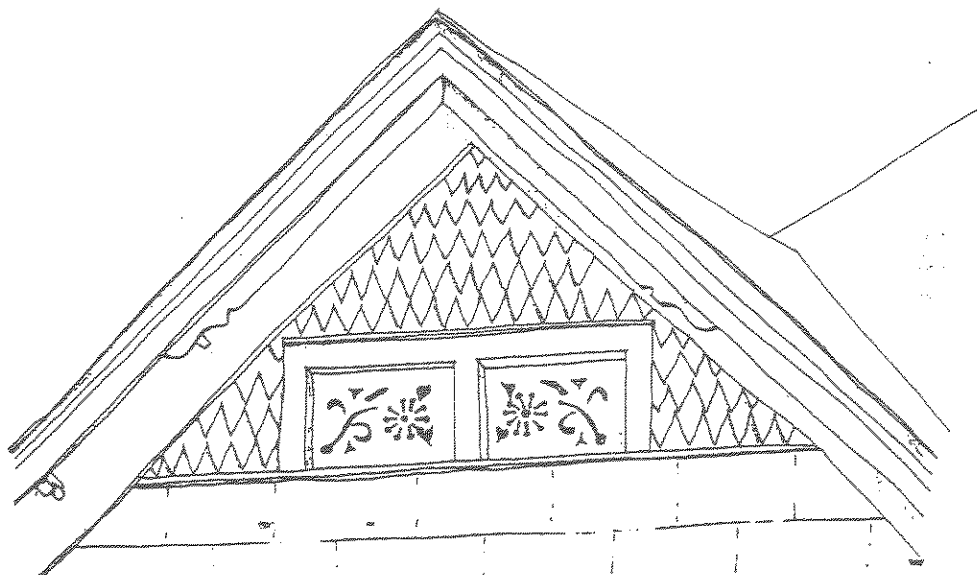

This trimwork at 4318 Alabama Avenue should be maintained and preserved.

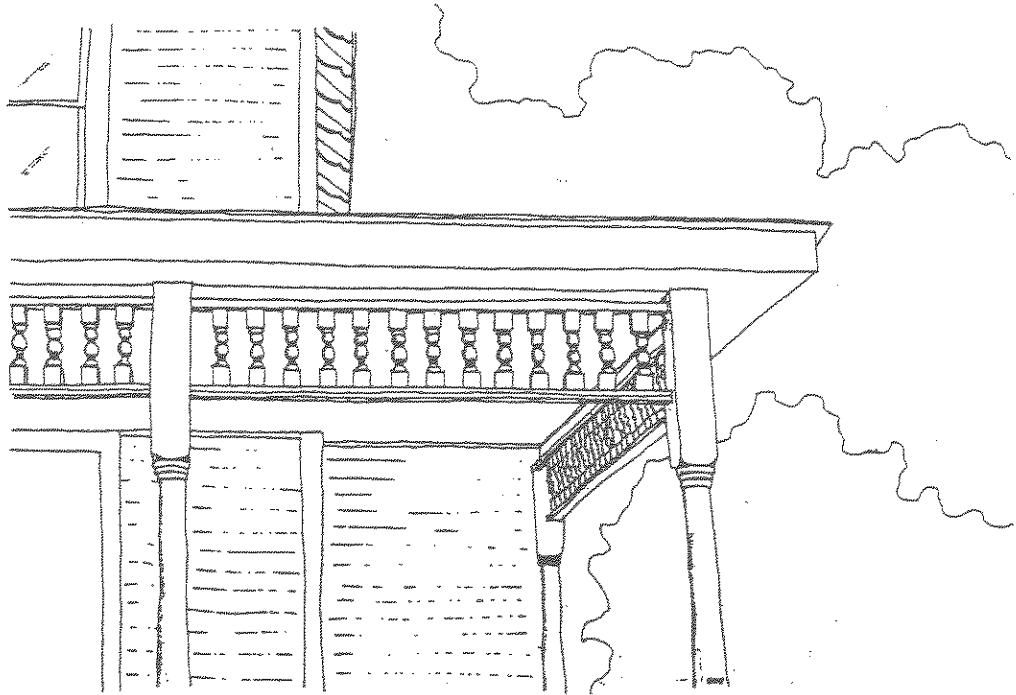

Porch frieze at 1610 West 49th Street.

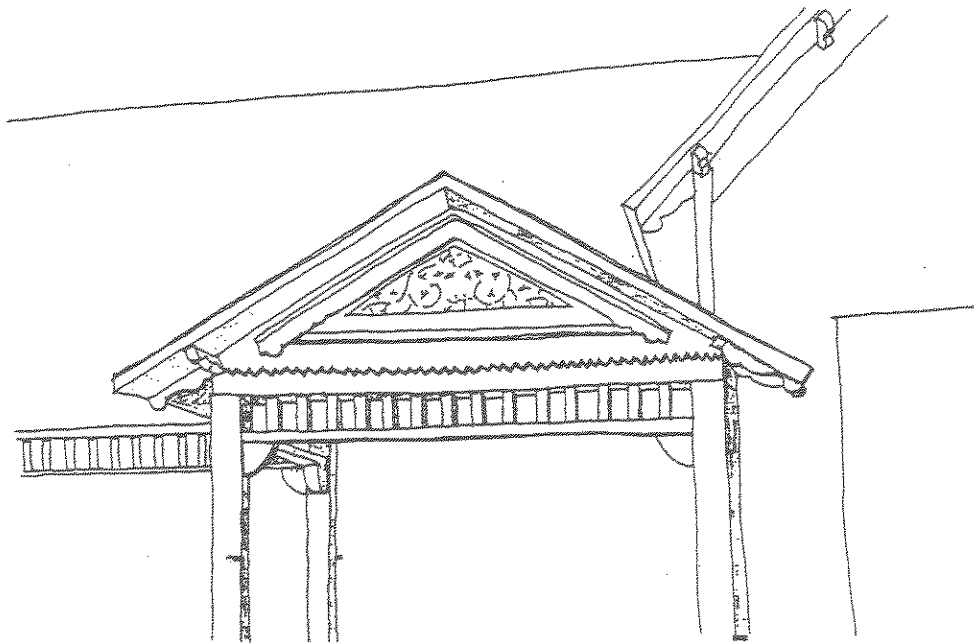

Porch detailing at 4406 Alabama Avenue.

3. AWNINGS

Canvas awnings for windows and porches were common features of St. Elmo buildings in the early 20th century. With the widespread use of air conditioning after World War II, the use of awnings declined. In recent years the use of awnings has increased because they are attractive and save energy costs. Canvas and similar material awnings are just fine for St. Elmo buildings.

- A. may be added on buildings at traditional locations such as over windows and doors and attached to porches.
- B. should be of canvas, vinyl-coated, or acrylic material.
- C. should not cover or conceal significant architectural details.
- D. should be of colors to blend with the building.
- E. should be made to fit the opening. Rectangular window and door openings should have straight across shed type awnings, not bubble or curved forms. Awnings over windows with rounded or oval shapes should have curved awnings to match the opening.

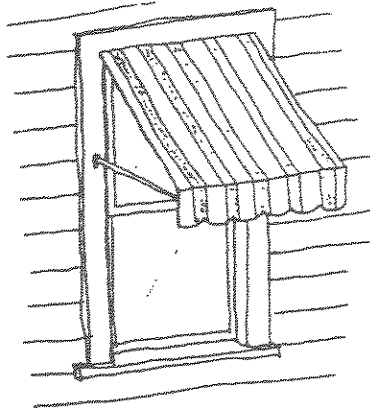

Rectangular openings should have shed awnings.

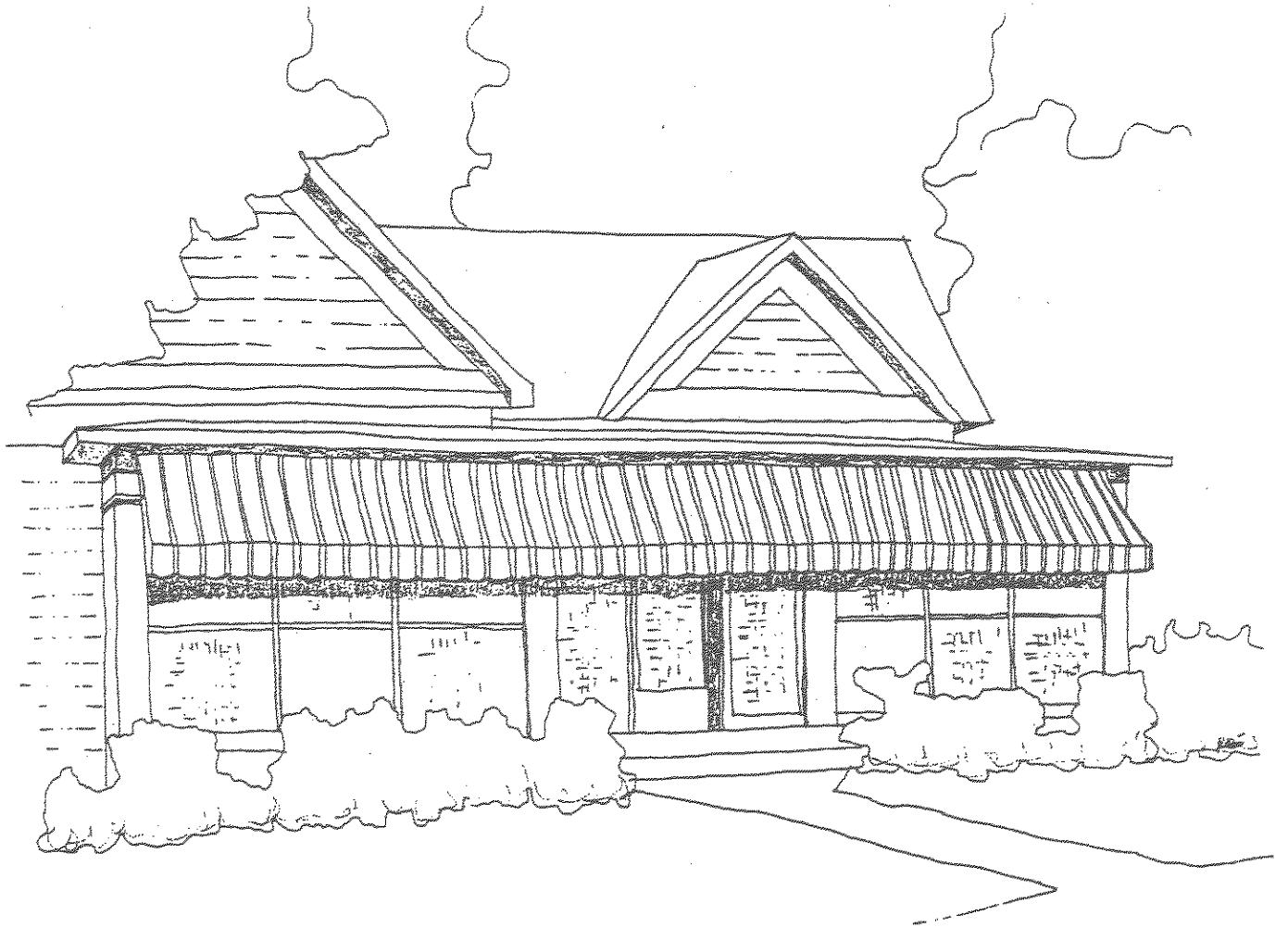

Appropriate porch awning at 4623 Tennessee Avenue.

4. BRICKWORK AND MORTAR

Many of St. Elmo's buildings are of brick or brick veneer construction. Brick can last for hundreds of years if it is well maintained. The key to brick and mortar preservation is to keep out water and continue to use a soft mortar when repair is needed. Abrasive cleaning such as sandblasting erodes the skin of the brick and can cause water to get inside. The use of hard mortars like Portland cement can cause the brick to crack and break when it can't expand and contract with the hot and cold weather. Low pressure cleaning like using a garden hose and the use of soft mortar mixes are best for St. Elmo's brick buildings.

- A. materials original to the building should be preserved and maintained.
- B. should never be sandblasted or subjected to any kind of abrasive cleaning.
- C. should never be cleaned with high pressure water which exceeds 600 pounds per square inch.
- D. should be cleaned with detergent cleansers if needed. If brick walls have bad stains or you want to take the paint off its fine to use chemical stain and paint removers. Chemical cleaning can be tricky and messy so you may want to call professionals for these kind of jobs.
- E. should be cleaned only when necessary to remove bad stains or paint build up. If there are only a few small stains or a little dirt on the walls it may be best to leave it alone. You don't want to put water or chemicals into your brick walls if you can help it.
- F. water-repellent coatings should not be added unless repairs have failed to stop water getting into your brick.
- G. should not be covered with silicone-based water sealants. Water sealants can have the affect of trapping water on the interior of the building and that can damage your inside walls.
- H. which has never been painted should not be painted unless the brick and mortar is extremely mismatched from earlier repairs or patching. Previously sandblasted brick or brick which is in poor condition may be painted to provide a sealing coat.
- I. should not be stuccoed.
- J. repairs should be done carefully to match the original brickwork and mortar, using hand tools, not electric power saws, to remove mortar.
- K. repointing (fixing the mortar between the bricks) should match the original brick and mortar regarding width, depth, color, raking profile, composition, and texture.

- L. repointing should never be done with Portland cement or other hard mortars but with soft mortars to match the original composition. If the original composition can't be determined, use a historic compound such as one part lime and two parts sand.
- M. features that are missing may be replaced with other brick to match. Salvage companies may have molded or decorative bricks to match those missing on a building.

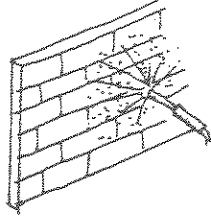

Sandblasting damages brick and erodes mortar joints.

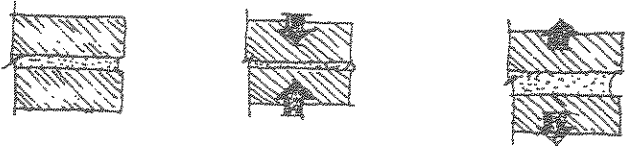

Mortar composition should allow brick to expand and contract.

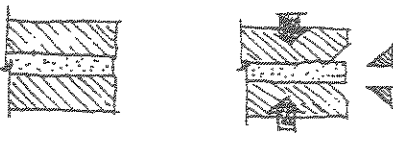

Hard Mortar or cement can cause spalling and cracking.

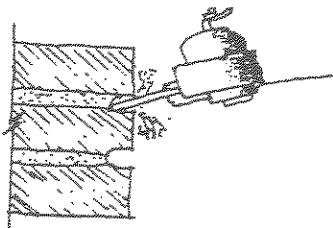

No

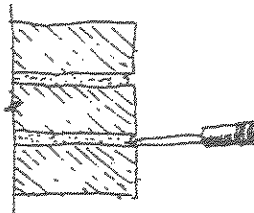

Yes

Use hand chisels, not power tools, to remove mortar.

5. CHIMNEYS

Chimneys often feature decorative brickwork or designs which contribute to a building's architectural character. For some Tudor Revival and Craftsman/Bungalow dwellings, chimneys on the front of the house are important to its style. Chimneys should be maintained and preserved in accordance with the brick and mortar guidelines.

- A. should not be removed or altered if original.
- B. should be repointed and cleaned according to masonry guidelines to match original materials, colors, shape, and brick pattern. If chimneys have been extensively repointed resulting in mismatched colors and textures, painting the chimney dark red or brown is appropriate.
- C. should match their original design if they have to be rebuilt due to becoming unstable or if they are falling down.
- D. should have clay, slate, or stone caps. Stay away from the metal caps unless they fit right in the top of the chimney and are not easily seen.
- E. should not be covered with stucco or other veneers.

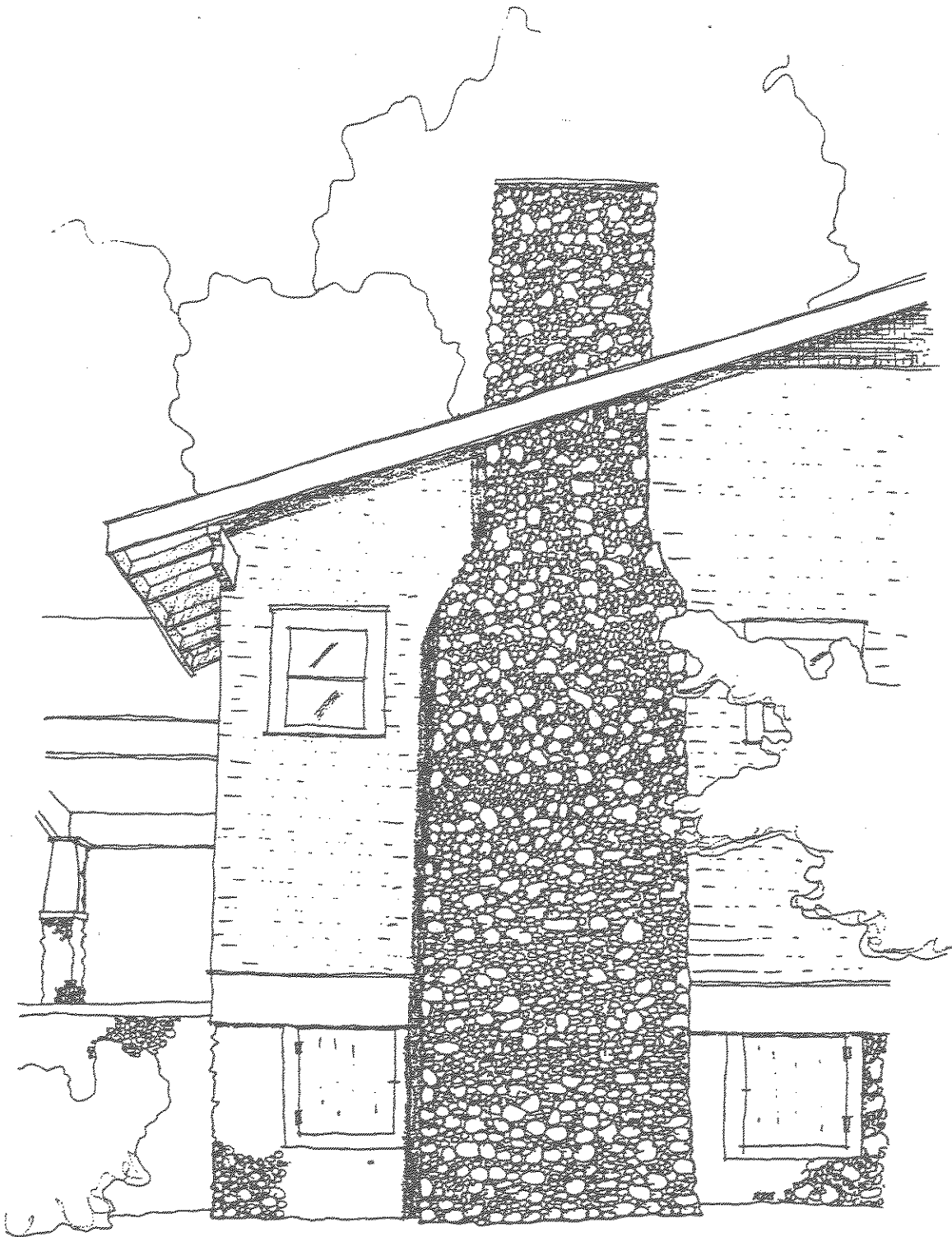

A stone chimney at 4218 Tennessee Avenue.

6. DECKS

Outdoor wood decks are popular additions and can usually work well with older buildings. As in the case of adding rooms, wood decks should be only built at the rear of buildings. Decks on the sides of buildings are also fine if they are not readily visible from the street.

- A. should be located at the rear of buildings. If built on the side of a building the deck should be screened from street view with fencing and/or native evergreen plants and shrubs.
- B. should be stained or painted to match or blend with the colors of the building if readily visible from a street view.
- C. should be simple rather than ornate in design. If readily visible from the street, wood decks are recommended to have square wood balusters set no more than three inches apart. Balusters should be no more than 2" in width and depth.

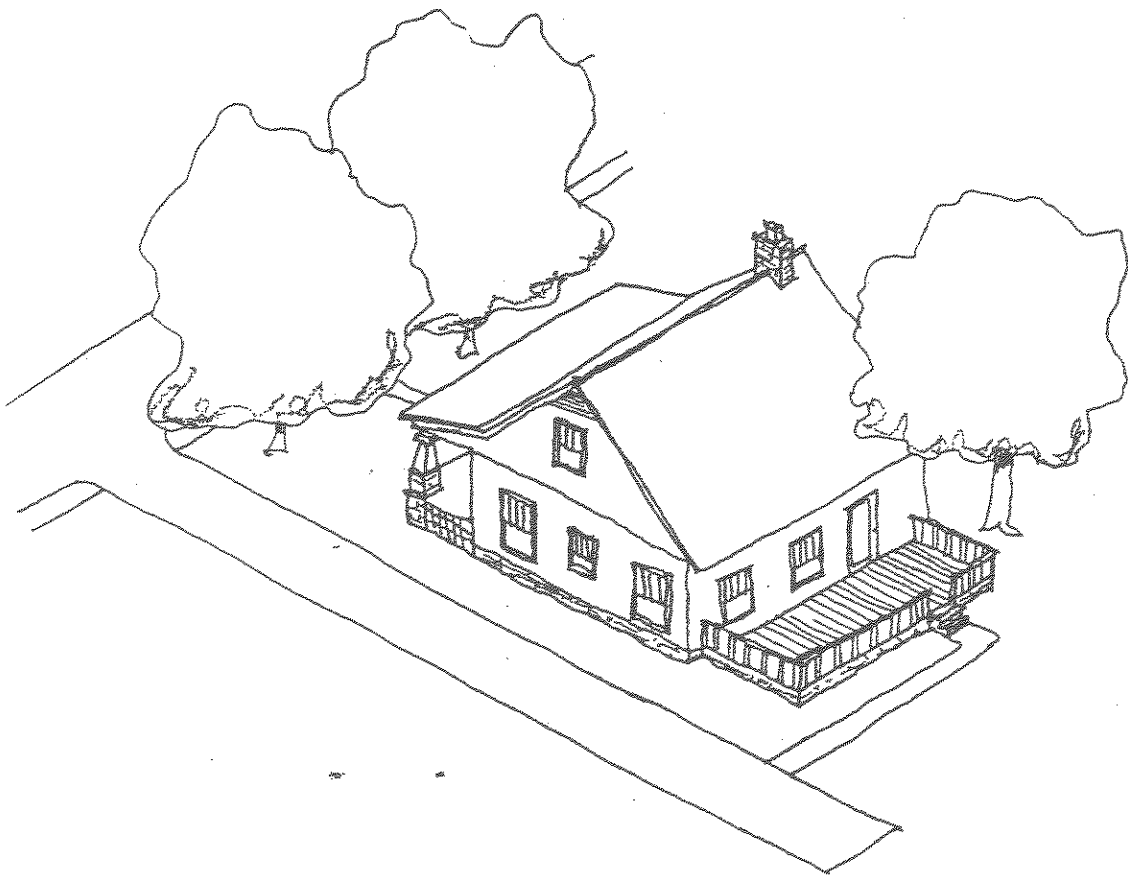

Acceptable rear deck design.

7. DEMOLITION

Demolition is forever and once a building is gone it takes away another piece of the neighborhood's character. Demolition of a historic building which has most of its original design and features should only be an action of last resort.

- A. of any original feature or part of a historic building should be avoided.
- B. of a building which contributes to the historic or architectural significance of the St. Elmo Historic District should not occur, unless:
 - 1. public safety and welfare requires the removal of the building or structure;
 - 2. if a building has lost its architectural and historical value and its removal will improve the appearance of the neighborhood;
 - 3. if a building does not contribute to the historical or architectural character and importance of the district and its removal will improve the appearance of the neighborhood; or
 - 4. if the denial of the demolition will result in an economic hardship on the applicant as determined by Section VIII of the Ordinance.
- C. of pre-1945 secondary buildings (garages, etc.) may be appropriate if substantially deteriorated (requiring 50% or more replacement of exterior siding, roof rafters, surface materials, and structural members).

8. DOORS

Doors and door surrounds are important features in defining the style and character of a building. Original doors should be preserved and maintained and original features should be repaired rather than replaced.

- A. and/or their surrounds, sidelights, transoms, and detailing should not be removed or altered.
- B. new doors should not replace historic doors at the front entrance or at side entrances which are readily visible from the street.
- C. of historic designs which are missing should be replaced with new doors appropriate for the style and period of the building. In replacing missing original doors, replacement doors should be similar in design to the original in style, materials, glazing (glass area) and lights (pane configuration). If the original design is unknown, a secondary entrance may contain an original door which can be moved to the main entrance. Salvage companies may also have historic doors available.
- D. of solid six-panel or flush wood or steel design should be used only for rear entrances or side entrances which are not readily visible from the street.
- E. of "decorator" designs available from wholesale hardware stores usually don't work for front entrances. These doors are not similar enough to the historic door designs of St. Elmo buildings. Doors with fake leaded glass inset designs also don't work for front entrances. For Craftsman/Bungalow dwellings, fifteen-light wood doors are readily available from wholesale stores and are acceptable for front entrances.
- F. if doors are introduced where none existed originally, they should be added at the rear or sides of buildings where not readily visible.

Screen doors:

- A. should be preserved and maintained if original.
- B. if new, should be wood and full-view or with structural members aligned with those of the original door.

Storm doors:

- A. should be full-view and baked-on enamel or anodized aluminum in dark colors. Storm doors with brass dividers or beveled glass are fine as long as most of the historic door remains visible.

Security doors:

- A. are not usually appropriate at the front entrance or entrances. However, security doors may be appropriate at front door locations if they are of full-view design, without ornate or decorative grillwork.
- B. which have extensive grillwork or structural frames are acceptable for rear entrances or side entrances which are not readily visible from the street.

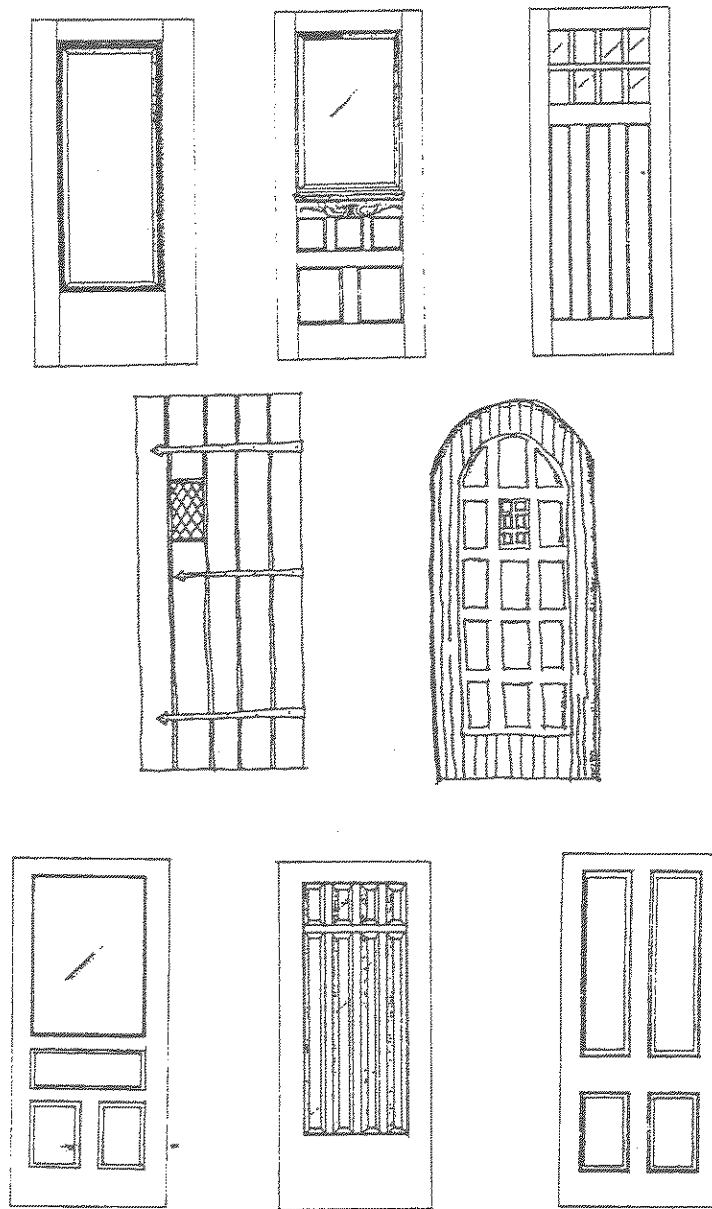

Common Craftsman and Tudor Revival door designs in St. Elmo.

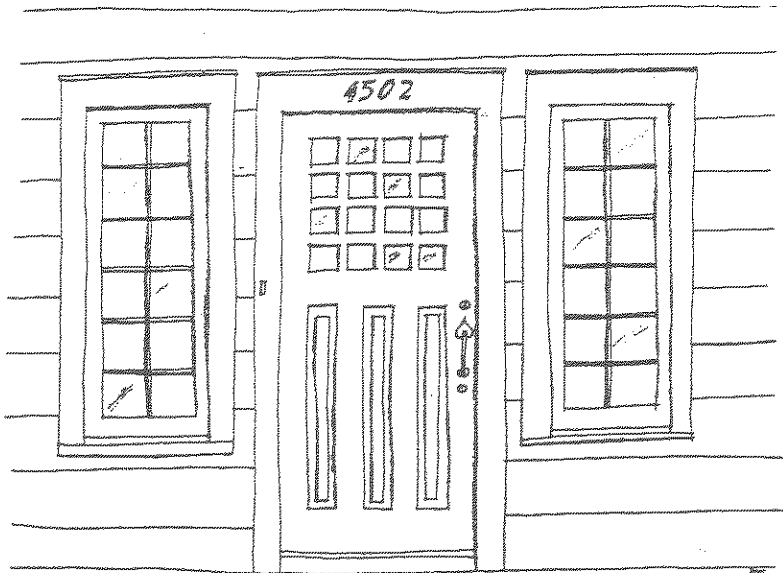

Multi-pane door at 4502 Alabama Avenue.



Multi-pane door with sidelights at 4401 Tennessee Avenue.

9. DRIVEWAYS & PAVING

Access to the buildings in St. Elmo is generally from rear alleys and new driveways for buildings should also be added at the rear of the lot. The popularity of the Craftsman/Bungalow style coincided with the rise in automobile ownership and many of these dwellings have side lot driveways and original garages. Within the district historic driveway materials such as concrete should be preserved and new driveways should be designed with traditional materials and placement.

- A. and their original designs, materials, and placement should be preserved.
- B. which are new, should be located at the rear with access from the alley.
- C. in the front or side yards should be of gravel (white or pea gravel), concrete, or concrete tracks (narrow strips). Blacktop or asphalt driveways may be approved but this material is not traditional to the neighborhood and should be avoided.
- D. should have their parking areas located in the rear yard nearer the alley than the building and screened with hedges, shrubs, or fences where noticeable from the street.
- E. of semi-circular design should not be sited in front yards.
- F. requiring new curb cuts to access driveways and parking lots should be kept to a minimum. The addition of curb cuts usually results in the removal of historic sidewalk materials, curbs, and retaining walls. Access through rear alleys is better than adding new curb cuts.

Traditional paving materials for driveways include gravel and concrete which are more appropriate materials than aggregate or asphalt. Textured concrete designed to look like brick pavers is also an appropriate material. As an aspect of landscaping, paving materials are not subject to Historic Zoning requirements. However, the use of appropriate materials such as gravel and concrete are recommended.

- A. should be gravel or smooth concrete instead of asphalt or aggregate for houses.
- B. of concrete "ribbons" or narrow tracks are traditional for driveways leading from the street and is encouraged for new driveway designs.

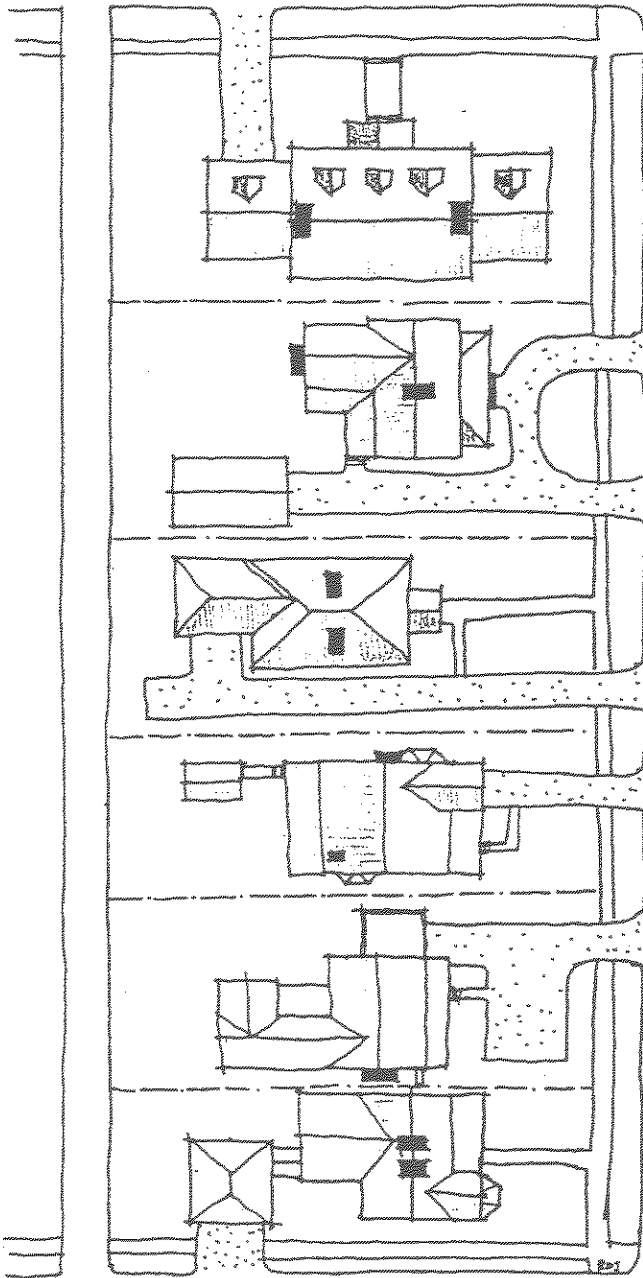

No - Orientation towards side street.

No - Circular driveways in front of house.

Yes - Driveway to rear garage.

No - Garage attached to front of the house.

No - Parking in front of house.

Yes - Access to garage from side street.

Driveway locations for St. Elmo.

10. FANS

Although not common, ceiling fans were sometimes added to front and side porches to assist in air circulation. New ceiling fans for porches on rear or side facades are appropriate. New ceiling fans on front porches are non-historic additions and are discouraged.

- A. mounted on ceilings at rear porches or porches on non-readily visible sides of buildings are appropriate.
- B. should not be added on the ceilings of porches on the front of the building.
- C. exterior fans should be simple in design and be mounted flush with the ceiling.

11. FENCES

Wood fences were widely used in St. Elmo to separate lots and outline front yards. Cast iron, brick, stone, and wire fences were also used in the district. In recent decades chain link fences have been popular. Historic (pre-1945) fences should be preserved and maintained. The construction of new fences based upon historic designs and materials is also appropriate.

- A. of cast iron, stone, metal (wire) or brick that are original to the building (or built before 1945) should be preserved, or if missing, may be reconstructed based on physical or pictorial evidence.
- B. of cast iron may be added to buildings constructed in the late 19th and early 20th century. Cast iron fences are not appropriate for Bungalow/Craftsman style dwellings or for other designs built after 1920.
- C. of wood pickets are fine for front or rear yards, generally following property lines, and should be painted or stained light, pale white or beige tones. Wood fences should be no taller than three feet, have pickets no wider than four inches and set no farther apart than three inches. Wire fences should also not be more than three feet tall.
- D. of wood boards for privacy should be located in rear yards and generally be no taller than six feet (most pre-fab wood fence sections are 8' wide by 6' high). Privacy fences of this height should be at least half-way back from the front to the back walls on the side of the house. Privacy fences of flat boards in a single row are preferred to shadowbox (alternating boards) designs. Fences with flat tops, "dog ear", or Gothic (pointed tops) designs are all acceptable. "Stockade" designs are discouraged. Fences should be stained or painted to blend with the dwelling or building.
- E. of free-standing brick or concrete walls are not appropriate in front yards but are acceptable at rear yards and side yards not readily visible from the street.
- F. of chain link are not appropriate for front yards. Chain link is not an historic fence material and wood picket fences or wire fences are much better. Chain link fences are acceptable in rear yards or side yards, preferably where not readily visible from the street. The painting of visible sections of chain link fences in dark green or black colors is recommended. Plastic coatings for chain link fences in green and black colors are also available and are recommended. The screening of chain link fences with hedge, ivy, or other creeping cover is also encouraged.
- G. of split or horizontal rails, and of railroad ties or timbers, whether freestanding or as retaining walls, are not appropriate for front yards but may be added at rear yards or non readily visible side yards.

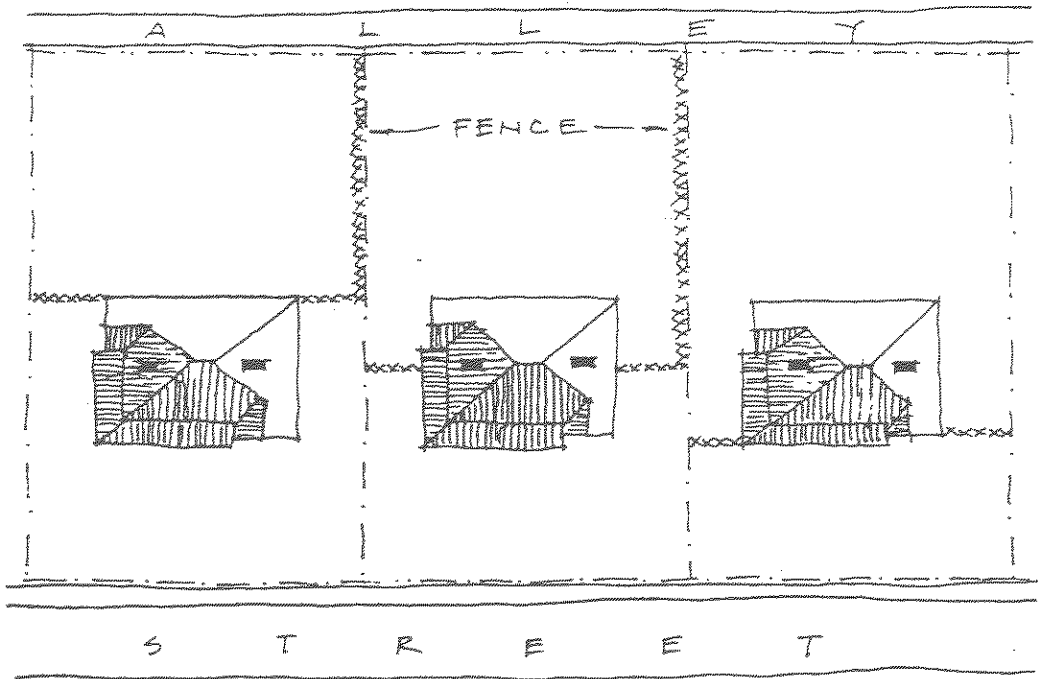

Yes

Yes

No

Acceptable fencing locations.

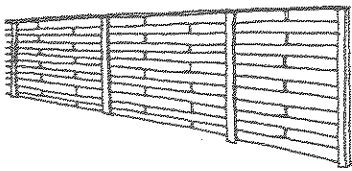

No

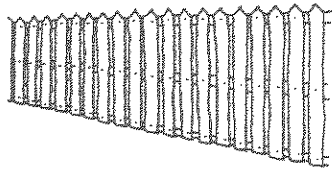
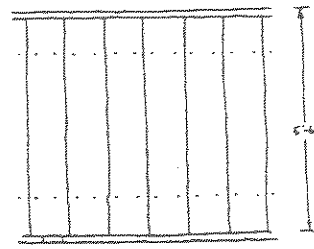

Yes

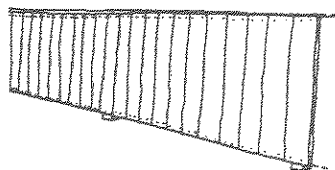

Yes

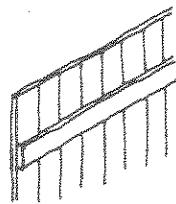

Better

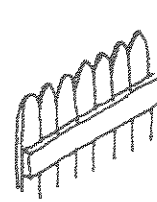

Acceptable

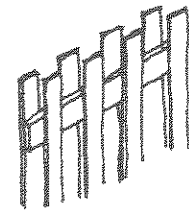

Acceptable

Appropriate board fencing designs.

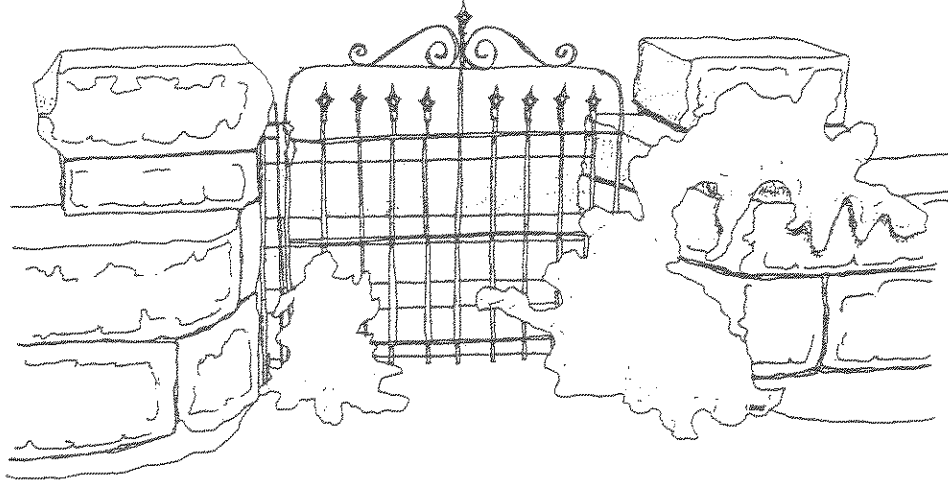

Cast iron gate and stone fencing at 4300 Alabama Avenue.

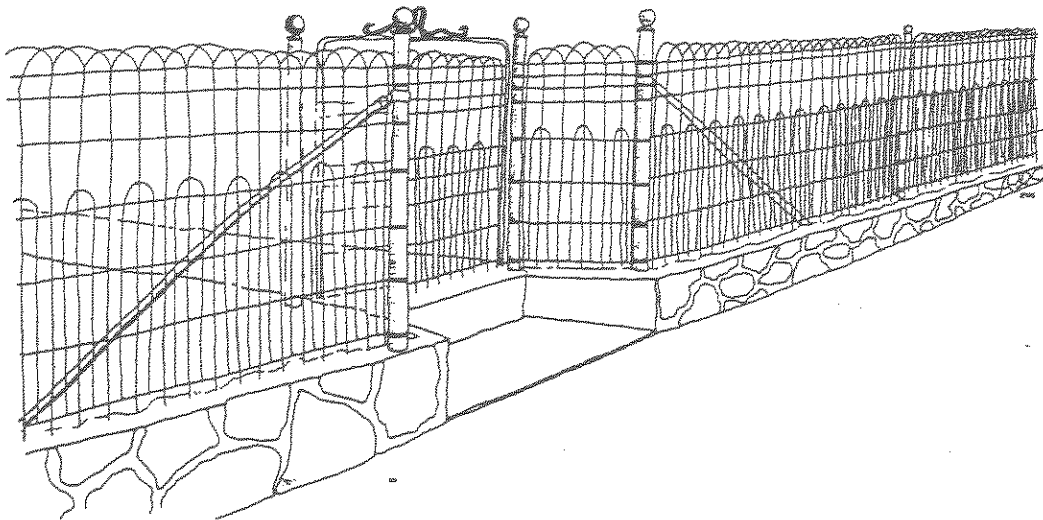

St. Elmo's collection of historic cast iron and wire (shown) fencing should be preserved and maintained.

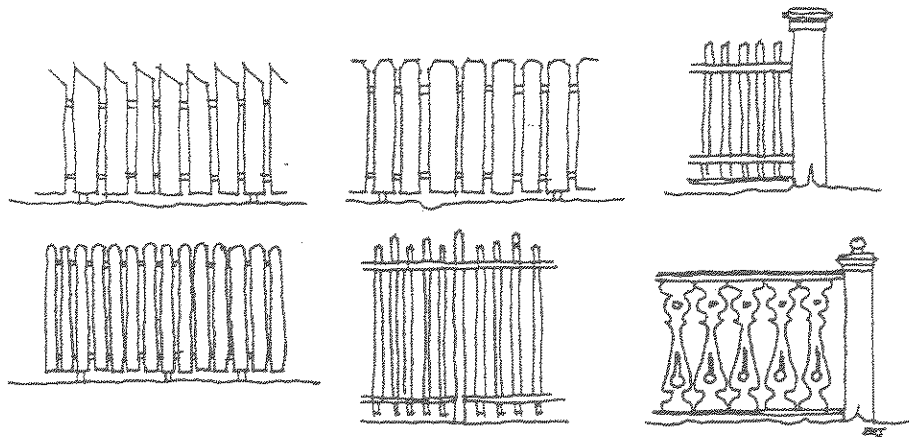

Appropriate picket fence designs.

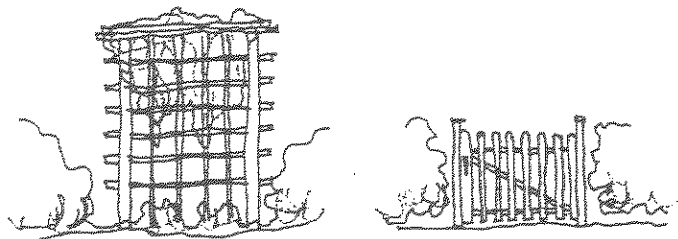

Wood trellises and wood gates are also appropriate.

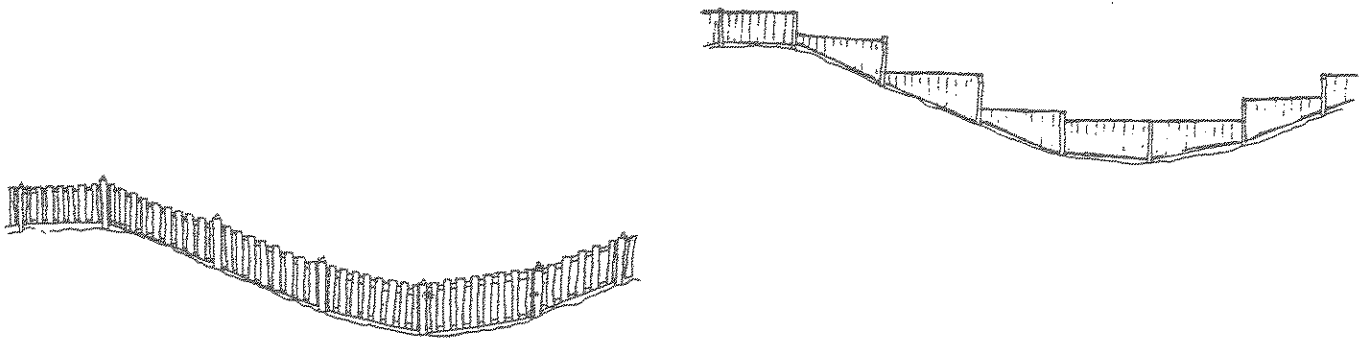

New fencing should follow slope contours.

12. FIRE ESCAPES

Multi-story buildings used for commercial and/or rental residential uses often require fire escapes to meet fire and safety codes. Fire escapes, whether incorporated within the walls of the building or attached to exterior walls, should be sited at the rear or sides of buildings which are not readily visible from the street.

- A. should not be added unless required by building codes or where no other means of upper floor access is reasonably feasible.
- B. should be located where they will not be readily visible from the street.

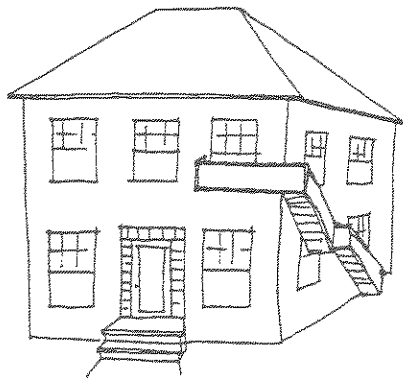

No

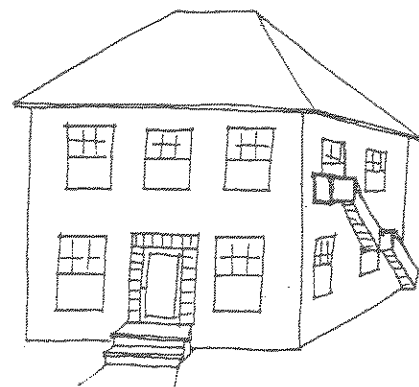

Yes

Fire escapes should be on the rear or sides, not the front of a building.

13. FOUNDATIONS

Many St. Elmo dwellings have finely crafted foundations of native stone and brick is also widely used as a foundation material. Repointing and repair of masonry foundations should follow masonry guidelines.

- A. should be preserved and maintained in their original design and with original materials and detailing.
- B. between existing piers should be filled in as traditional for the type and style of the house, generally with wood lattice framed panels; with brick of color, tooling, and mortar color appropriate for the period of the house, or with decorative vertical wood boards.
- C. should not be concealed with concrete block, plywood panels, corrugated metal, or wood shingles.
- D. if masonry, should be cleaned, repaired, or repointed according to masonry guidelines.
- E. of brick may be painted or stuccoed if the brick and/or mortar is mismatched or inappropriately repaired. Dark reds, browns or other traditional brick colors are appropriate paint colors for foundations.

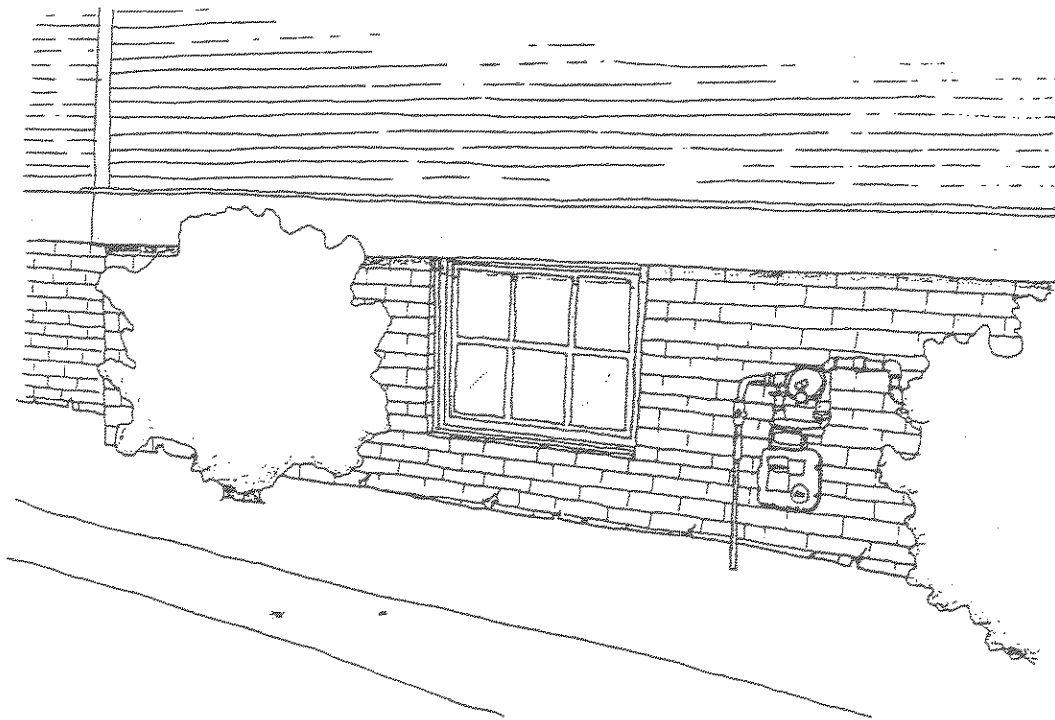

Typical brick foundation.

14. GARBAGE COLLECTORS

Garbage collectors (cans, dumpsters, etc.) should be located at the rear of buildings or along alleys. Large garbage collectors at the rear of commercial buildings should be screened with landscaping or wood panels such as lattice.

- A. for institutional and commercial structures, garbage collectors should be located at the rears of buildings and be screened from the street view with fencing or shrubbery.

15. GUTTERS

Deteriorated gutters and downspouts can cause extensive damage to building materials and detailing. Existing gutters should be regularly cleaned and maintained. If new gutters are required, half-round designs are the most historically accurate. If not readily available, "K" or ogee design gutters of aluminum or vinyl are acceptable.

- A. of boxed or built-in type should be repaired rather than replaced if possible.
- B. of hang-on type should be half-round rather than "K" or ogee. If half-round gutters are not easily available, ogee gutters of aluminum or vinyl are acceptable.
- C. should have downspouts located away from significant architectural features on the front of the building.
- D. should provide proper drainage through use of downspouts and splashblocks to avoid water damage to the building.

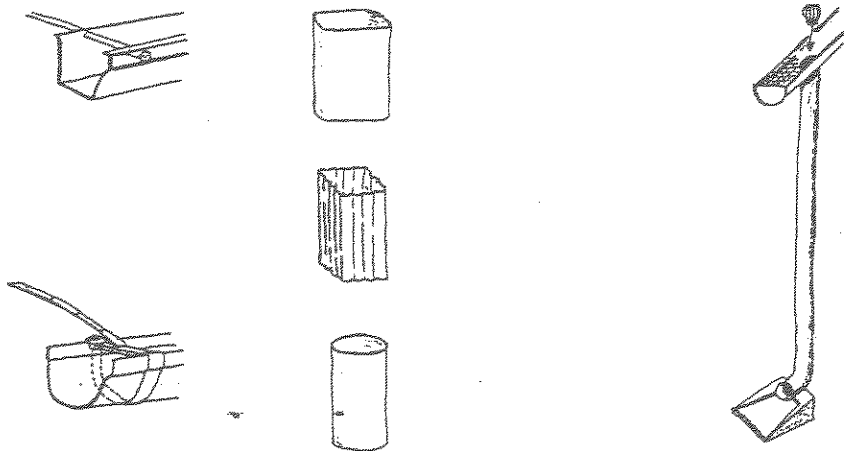

Gutter and downspout designs.

16. HANDICAPPED ACCESS RAMPS

Handicapped ramps are sometimes needed to provide access for those with disabilities. Handicapped access ramps are best at the rear or sides of buildings which are not readily visible from the street. Ramps of wood construction are most appropriate for St. Elmo and the railings should be with simple designs or match the original porch railing in design and detailing.

- A. preferably should be located at the rear or sides of buildings. If a handicapped ramp must be placed on the front of a building it should be of wood construction rather than of brick, concrete, or metal. Brick, concrete, and metal ramps are more acceptable at rear and sides of buildings not readily visible from the street.
- B. of wood construction should be simple in design and configuration using square balusters in the railing and simple square handrails. Ramps may also be designed to match the original porch railing in materials, dimensions, and detailing. Ramps should be painted to match the color of the porch railing or the match the overall paint color of the building.
- C. should be screened with landscaping of low shrubbery to provide concealment.

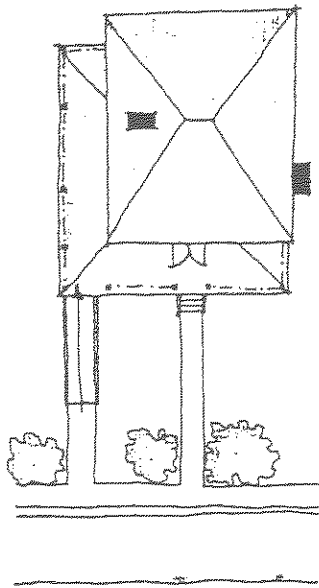

No

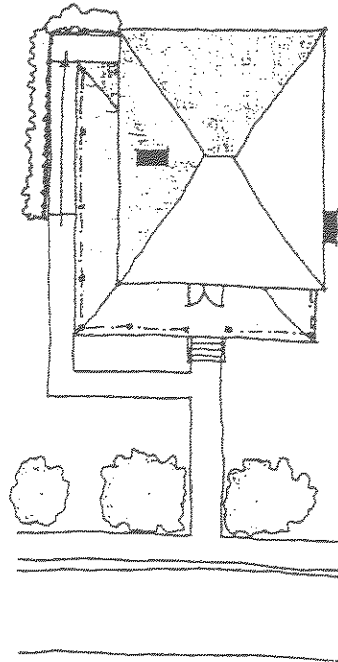

Yes

Handicap ramps should be at the rear or side of dwellings.



Appropriate handicap ramp design.

17. LANDSCAPING

Landscaping is not reviewed by the Historic Zoning Commission unless features such as historic retaining walls and fencing are affected. Although landscape planting does not require approval, a general rule of thumb to consider is to use landscape plants native to the area and traditional plants such as boxwoods, dogwoods, and azaleas; maintain, do not remove, historic or early landscaping, especially trees; keep new landscape patterns as historically traditional for the neighborhood; and avoid concealing architectural features of the historic building.

- A. features that are original or early (pre-1945) such as sidewalks, retaining walls, historic fence materials, curbs, stepping blocks, etc. should be preserved (See Section 11 on Fences).
- B. plant beds of railroad ties, cut wood, brick, concrete, or any other structural material should be avoided for front yards.

18. LIGHTING

Many dwellings retain original exterior light fixtures at the porch ceiling or adjacent to the main entrance. Distinctive tinted globes and the "box" shaped fixtures for Craftsman/Bungalows are part of a building's character and should be preserved and maintained. If the original light fixtures are missing, light fixtures with simple designs and detailing are preferred to large, ornate colonial or "Williamsburg" style fixtures. Many companies now provide light fixtures based upon historic designs and the addition of these types of period fixtures is appropriate and encouraged.

- A. fixtures original to the building should be preserved and maintained.
- B. fixtures introduced to the exterior of a structure should be from the period of the structure, or simple in design if new, based on traditional designs of the late nineteenth and early twentieth centuries, and mounted on porch ceilings or adjacent to entrances.
- C. for security, such as flood lights, should be mounted on rear or sides of buildings rather than on the front.
- D. for sidewalks and front yards should be of small footlights rather than post-mounted fixtures. Post-mounted fixtures are less appropriate but may be installed if desired.
- E. fixtures to be avoided are carriage lamps or any fixtures of a period earlier than the building such as colonial or "Williamsburg" designs.

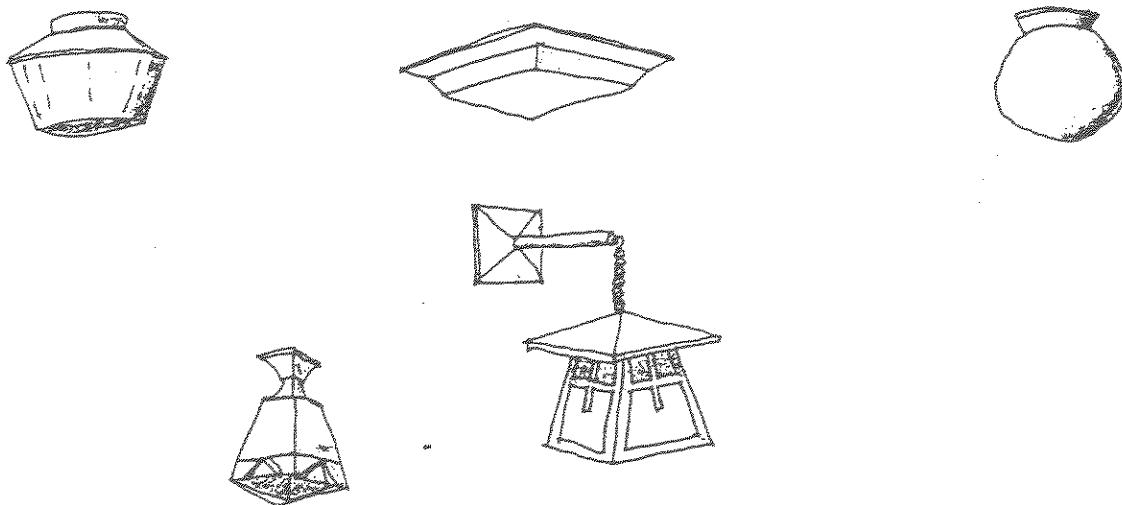

Acceptable light fixtures.

19. MASONRY (Stone)

Stone exteriors, foundations, and other features are integral to a dwelling's character and should be preserved and maintained. Stone retaining walls, gate posts, and other original landscape features should also be preserved and maintained.

- A. materials original to the building should be preserved and maintained.
- B. should never be sandblasted or subjected to any kind of abrasive cleaning.
- C. should never be cleaned with high pressure water which exceeds 600 pounds per square inch.
- D. should be cleaned with detergent cleansers or chemical agents by professionals.
- E. should be cleaned only when necessary to halt deterioration or remove heavy soiling to avoid needlessly introducing water or chemicals into the building.
- F. paint removal should not be done if the paint is firmly adhered to, and therefore protecting the stone surface.
- G. water-repellent coatings should not be added unless masonry repairs have failed to stop water penetration problems.
- H. should not be painted.
- I. should not be stuccoed.
- J. mortar between stones should be removed by hand tools, not electric power saws, for repairs.
- K. repointing should match original width, depth, color, raking profile, composition, and texture.
- L. repointing should never be done with Portland cement or other hard mortar but with an original compound if it can be determined or with a historic compound such as one part lime and two parts sand if it cannot.
- M. features that are missing may be replaced in-kind where missing, or when required by extensive deterioration if accurately duplicated.

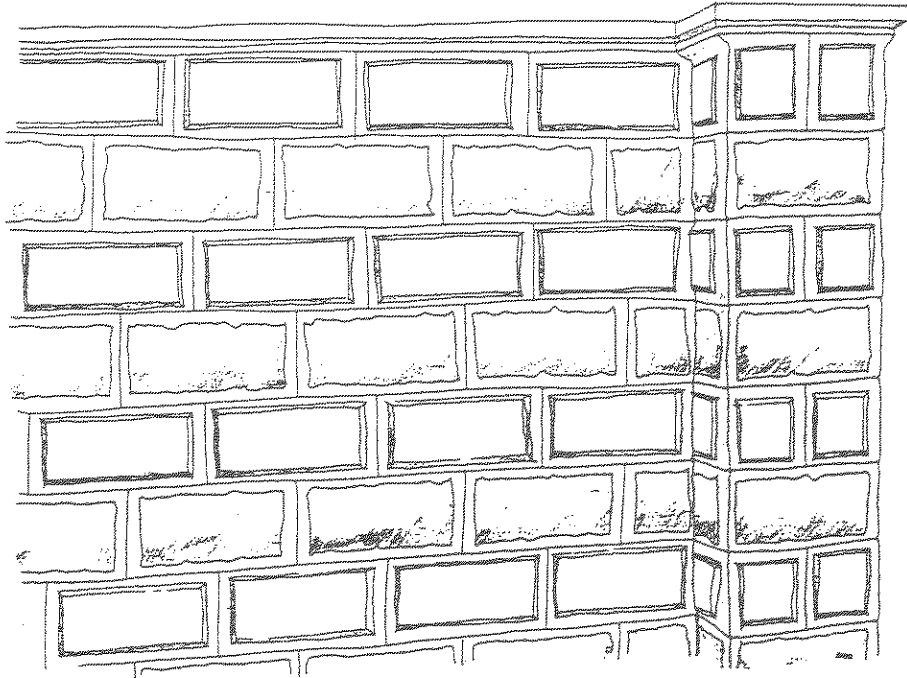

Masonry elements should be preserved and maintained (4105 St. Elmo).

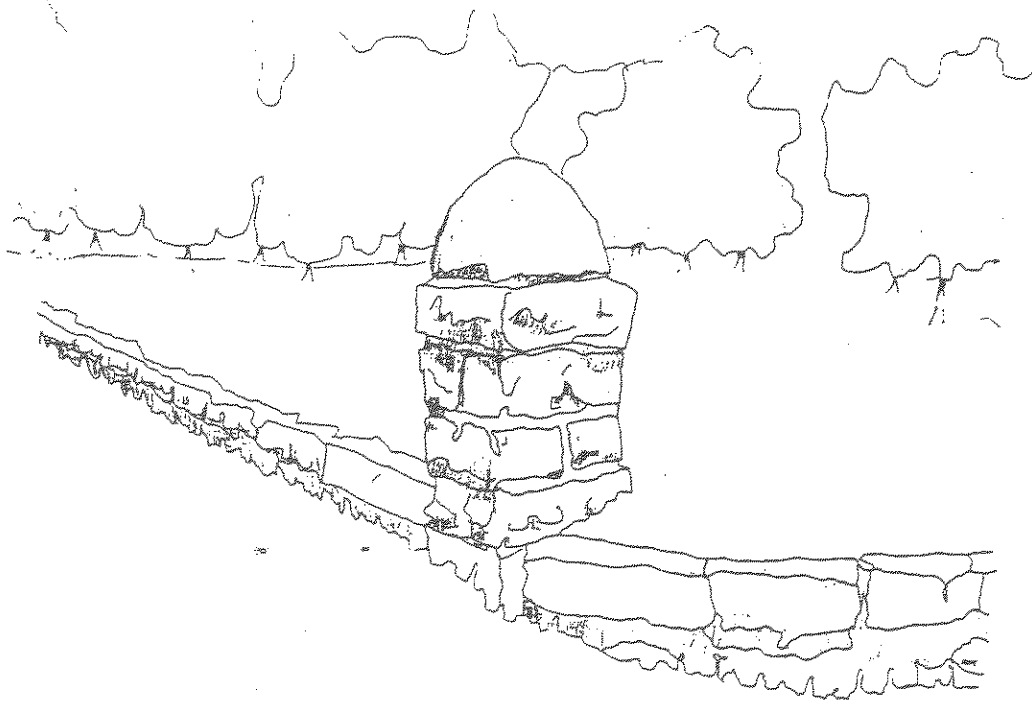

Stone retaining wall and cornerpost at 4150 Alabama Avenue.

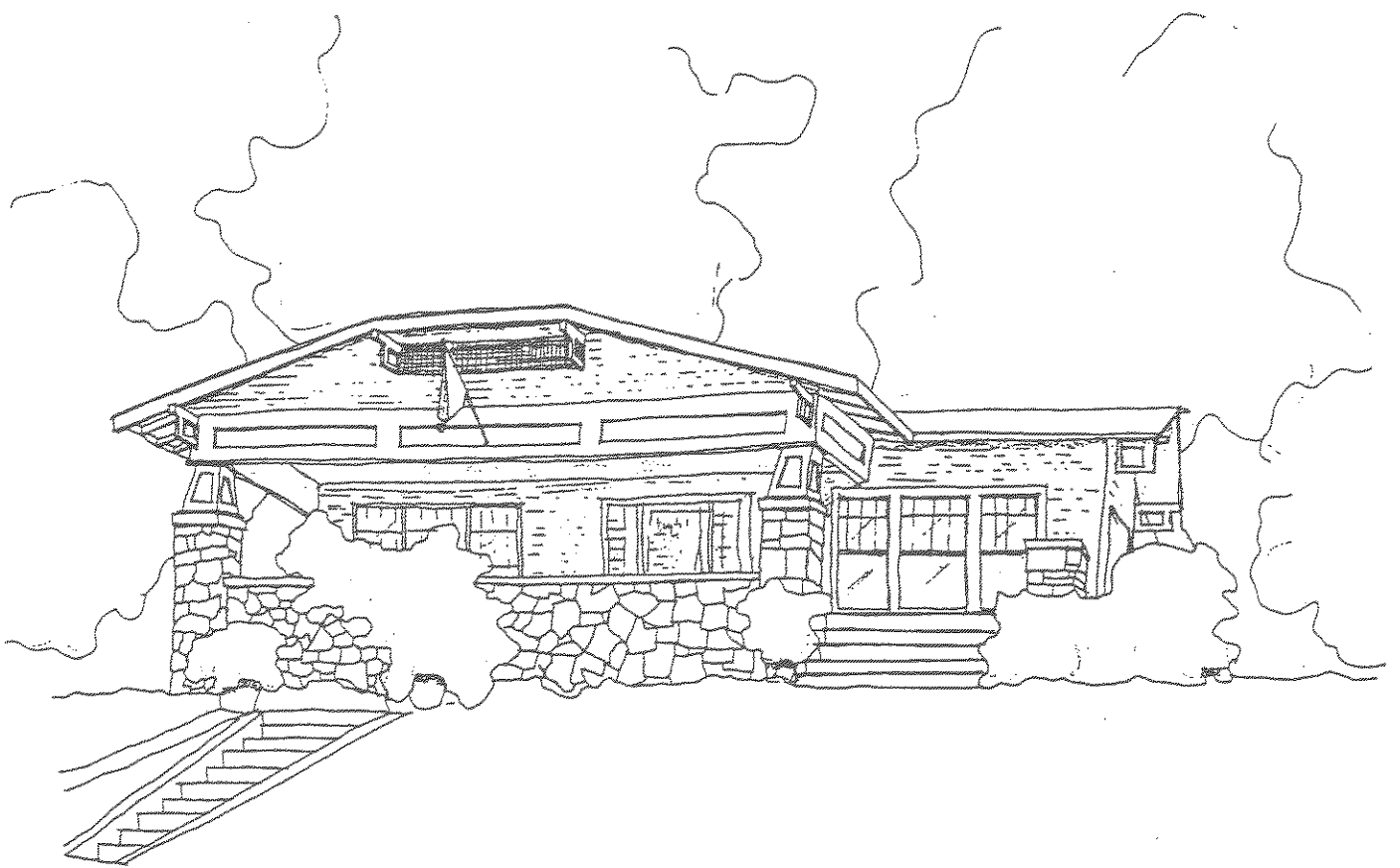

St. Elmo dwellings feature stone details such as foundations and porch columns (4630 Tennessee Avenue).

20. MECHANICAL SYSTEMS

Modern air conditioning and heating units often require condensers and other units to be placed on the exterior. These units are typically located adjacent to, or within a few feet of the building. Heating and cooling units should be placed at rear of sides of buildings not readily visible from the street. The placement of these units at the front of buildings is not appropriate and should be avoided. Screening of these units through shrubbery, fencing, or lattice panels is highly recommended.

- A. Heating and cooling units should be located where not they are not readily visible from the street.
- B. if visible on the sides of buildings, should be screened with shrubbery or fencing.
- C. such as window air-conditioners should be located in windows on the rear or sides of buildings and should not result in the removal or replacement of the original window sash or surround.
- D. such as solar energy panels should be located on rear sections of the roof, behind dormers or gables or other areas not visible from the street.
- E. satellite dishes should never be installed in front yards or where readily visible in side yards.
- F. electrical and gas meters and other mechanical equipment should be located on the rear or side of a building.

No

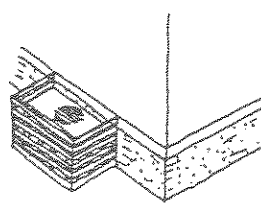
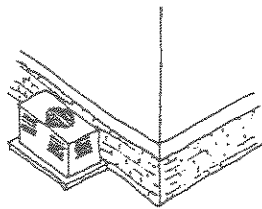

Yes

Yes

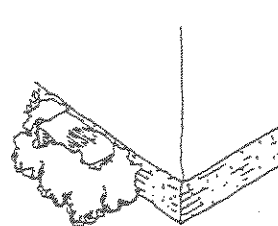
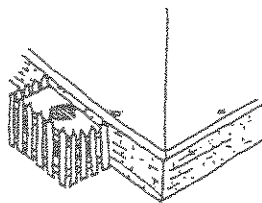

Yes

Appropriate HVAC screening.

21. MOVING BUILDINGS

St. Elmo possesses a number of vacant lots which are appropriate locations for new construction or the relocation of pre-1945 dwellings. Moving buildings is generally considered a last resort to demolition and should be considered only if other means of preservation have failed. If a pre-1945 dwelling within or outside the St. Elmo Historic District is threatened with demolition, it is appropriate to move the dwelling to one of the neighborhood's vacant lots for rehabilitation. A building moved into the district should respect the front and side yard setbacks, orientation, and foundation heights of the neighboring properties.

- A. into the historic district may be appropriate if compatible with the district's architectural character through style, period, height, scale, materials, setting, and placement on the lot.
- B. that contribute to the historic and architectural character of the district should be avoided unless demolition is the only alternative.

22. NEW CONSTRUCTION (New Buildings)

The vacant lots in St. Elmo provide development opportunities for new construction. New construction is welcome when it is compatible with properties along its block or street. The general approach to new construction is for it to be contemporary in design but compatible with adjacent buildings. Contemporary means clearly built of the present-day period so that new buildings can be distinguished from those which are historic. Compatible means reinforcing typical features that buildings display along the block such as similar roof forms, materials, window and door sizes and placement, porch size and location, and foundation heights. Exact replications or reproductions of historic designs are less appropriate since they cause confusion as to whether or not they are old or new. New construction should be of its period to show the growth and evolution of the neighborhood.

It is important that new construction coordinate with the dwellings found along its specific block. A design that may be appropriate along one block may not work for a different block. For example, a new dwelling compatible with Craftsman/Bungalow designs may not be appropriate for a block where Victorian era architecture predominates and vice versa. Each new building has to be evaluated within its exact location and surroundings.

- A. of primary buildings should maintain, not disrupt, the existing pattern of surrounding historic buildings along the street by being similar in:
 - 1. shape. Variations of rectangular and square forms are most appropriate for the district;

2. scale (height and width). Most of the district is zoned R-2 which restricts new construction to no more than two-and-one half stories or thirty-five feet in height. This maximum height would be appropriate for most blocks in the district. On blocks which have predominately one-story buildings, new construction of one-to two-stories would be more appropriate;
3. roof shape and pitch. Roof slope ratio for new construction should be a minimum of 6:12 to a maximum of 12:12 (6:12 refers to six inches of rise to 12 inches of run in measuring slopes). Roof forms of gable and hipped variations are more appropriate than those of flat, mansard, or gambrel forms. Flat roofs are appropriate only for commercial buildings;
4. orientation to the street. All buildings should have at least a secondary entrance and some type of entry porch on the front of the building. Most buildings in St. Elmo have their fronts oriented towards the street and this characteristic should be maintained by new construction;
5. location and proportion of porches, entrances, windows, and divisional bays. Porches should have roof forms of gable or shed design and at least cover the entrance. Porches which extend partially or fully across the main facade are recommended. Porch columns and railings should be simple in design in square or round shapes. Columns should be a minimum of six inches and a maximum of ten inches square or in diameter. Porch railings should have balusters which are no more than two inches square or in diameter. New windows should be rectangular sash whose proportions on the main facade should not exceed three-to-one in a height to width ratio or be any less than two to one in height-to-width (two to one proportions are preferred). No horizontal sash, casement, or awning type windows should be placed on the fronts of buildings. The use of plastic or "snap-in" muntins (window pane dividers) is discouraged;
6. foundation height. Height of foundations should be a minimum of 1 foot, six inches and a maximum of two feet above grade. No slab foundations or at-grade foundations should be utilized on the fronts or readily visible sides of buildings;
7. floor-to-ceiling heights. Floor to ceiling heights should not exceed ten feet and not be less than eight feet;
8. porch height and depth. Porch heights should be consistent with those of adjacent buildings. Porch depths should be a minimum of six feet;
9. material and material color.

Foundations: Most foundations are of brick, poured concrete or concrete block. Poured concrete is more appropriate than concrete block. If concrete block is used, a stucco wash is recommended to provide a smooth surface. Split faced concrete block is also an acceptable foundation material.

Brick Dwellings: If the new construction is of brick, the brick should closely match typical mortar and brick color tones found in the district and along the block. White or light mortars provide too much contrast with typical dark brick colors and should be avoided.

Frame Dwellings: If the new construction is of frame, the preferred exterior material is horizontal wood siding which is a minimum of four inches and a maximum of six inches in width. The use of masonite is also acceptable as long as it meets these size recommendations. The use of grained pressboard or chipboard is less appropriate but is acceptable if it meets these size recommendations. Vertical board siding is not appropriate for new construction on the fronts or sides of buildings. The use of vinyl or aluminum siding is also discouraged and should only be used on rear or non-readily visible sides of buildings.

Windows: Wood construction is preferred for windows, especially those on the fronts of buildings. However, the use of vinyl clad or aluminum windows is also acceptable as long as they follow proper proportions (see window guidelines). The use of dark anodized aluminum windows or storm windows is appropriate.

10. details and texture. The width of window and door trim should be at least three and one-half inches. Roof eaves should have a minimum depth of eight inches. No imitative architectural features such as vergeboard ("gingerbread"), roof balustrades, or prominent stained glass windows are appropriate for new construction.
11. placement on the lot. Front and side yard setbacks should respect the setbacks found along the block on which the building is sited. The minimum front yard setback under R-2 zoning is 25 feet. Requirements for side yard setbacks are a minimum of 10 feet.

B. of primary buildings, while blending in with adjacent buildings, should not be too imitative of historic styles so that new buildings can be distinguished from historic buildings.

NOTE: A new building becomes too imitative through application of historic architectural decoration such as gingerbread, vergeboards, dentils, fish scale shingles, etc. These kinds of details are rarely successful on a new building. They fail to be accurate (are usually smaller, skimpy, versions of authentic ones) and should be avoided.

- C. of secondary buildings such as garages, carports, and other outbuildings should be:
1. smaller in scale than the primary building;
 2. simple in design but reflecting the general character of the primary building. For example, use gable roof forms if the main dwelling has a gable roof, hipped roof forms if the main dwelling has a hipped roof etc.;
 3. located as traditional for the street, near an alley or at the side of the dwelling, not close to or attached to the primary building; and
 4. compatible in design, shape, materials, and roof shape to the main building.
 5. preferably of wood siding. However, if located along rear alleys or towards the rear of the lot, secondary buildings may have exterior siding materials such as masonite (preferred), aluminum, or vinyl. Along rear alleys or rear lot lines, standard pre-fabricated buildings are also acceptable.
 6. if readily visible from the street, secondary buildings should have an emphasis on historic designs and detailing. For garages wood paneled doors are more appropriate than paneled doors of vinyl, aluminum, or steel. Wood paneled overhead roll-up doors are widely available and are appropriate for new garages.
 7. if carports, these should be located at the rear of buildings. Most readily available carport designs have flat roofs and metal support columns and are not compatible with older building designs. Carports imitative of porte-cocheres (drive-thru wings on historic dwellings) with wood or brick columns, flat roofs, and wood construction may be added to sides of dwellings readily visible from the street.



New construction should maintain compatible roof slopes, massing and lot placement.

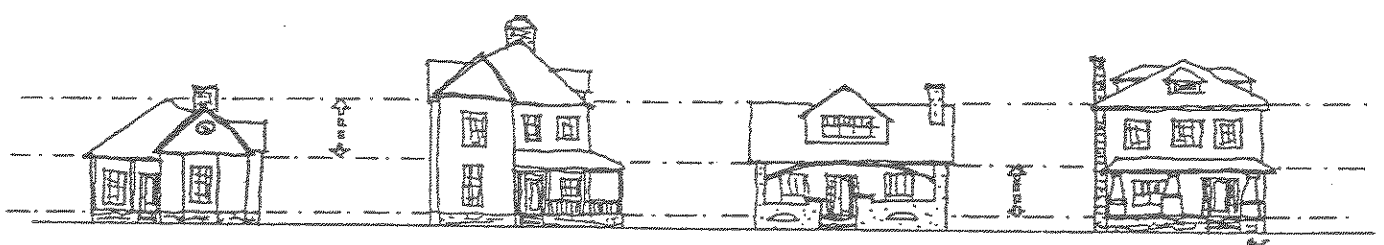

Floor-to ceiling heights should be maintained.

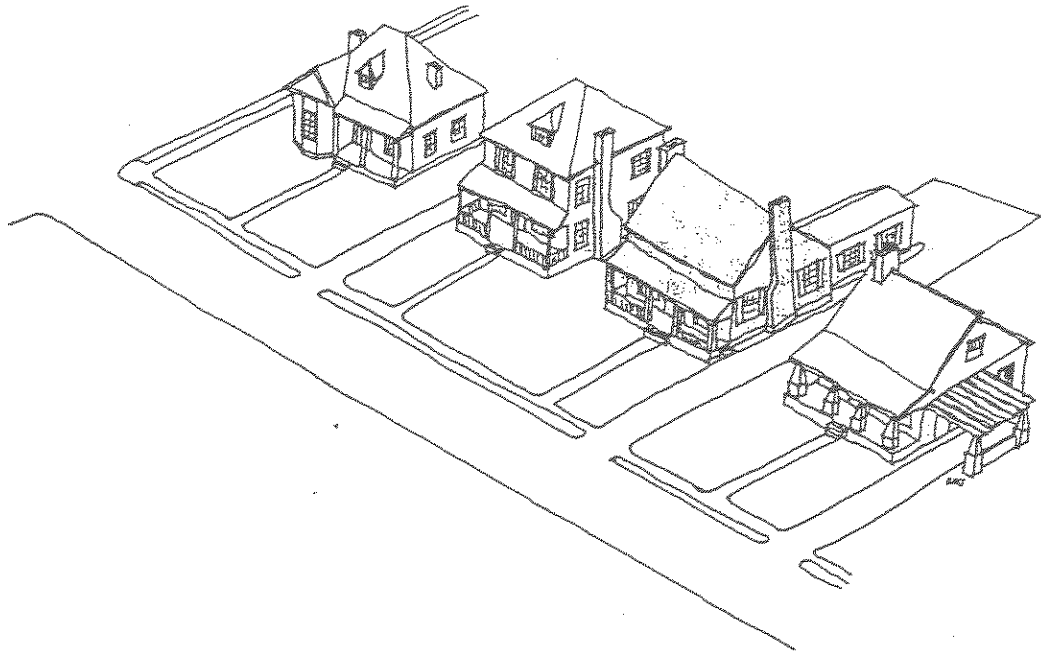

New construction should be comparable in orientation towards the street.

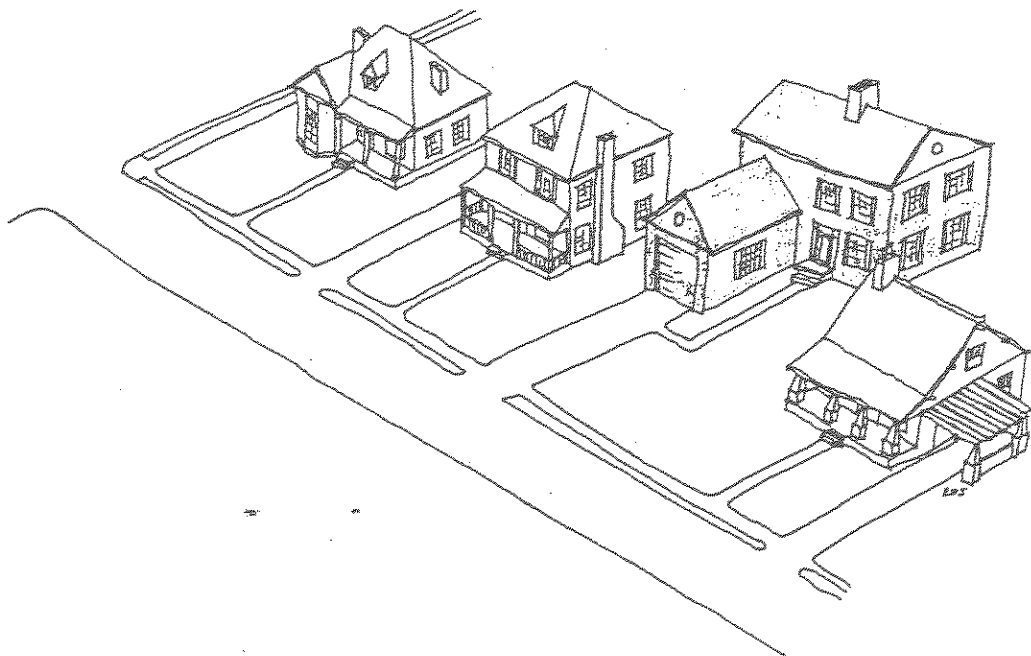

Inappropriate massing and orientation.

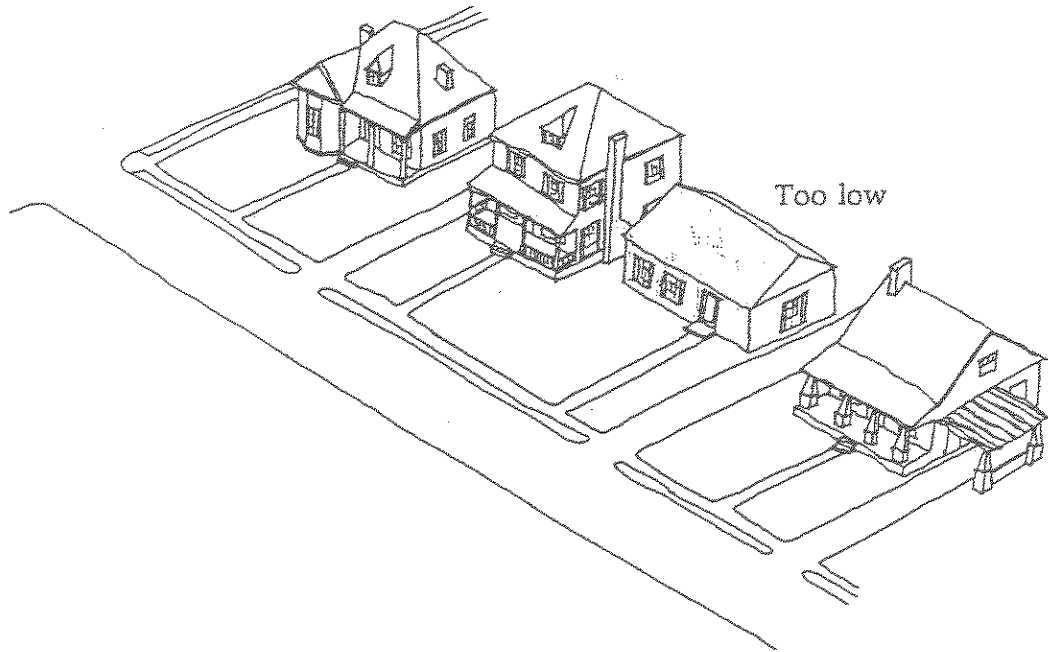

Building heights should be compatible with adjacent buildings.

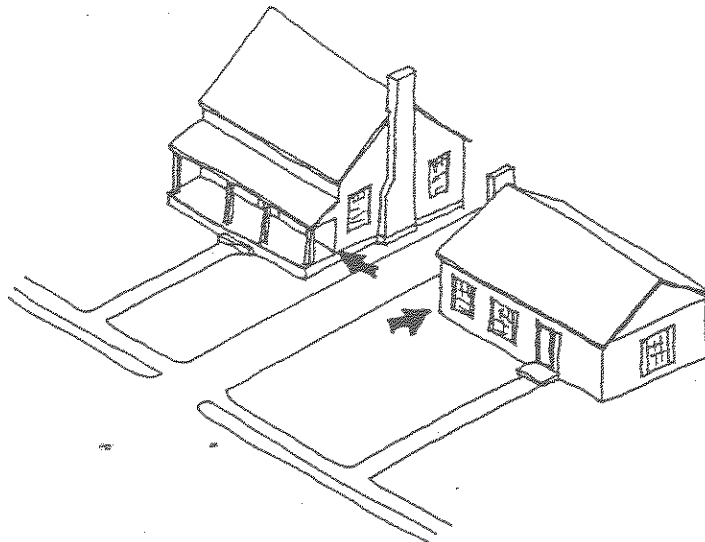

New construction should maintain typical foundation heights.

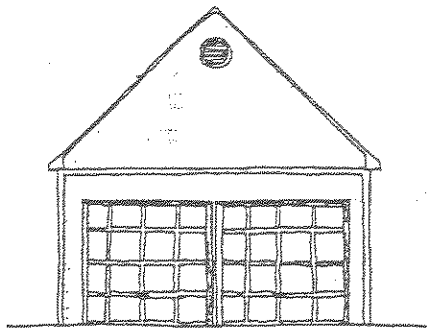

Appropriate

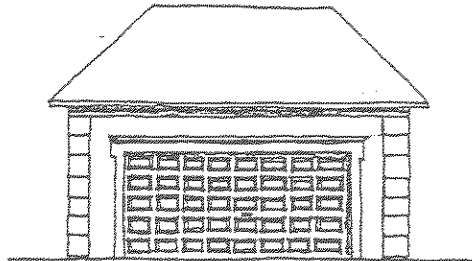

Acceptable

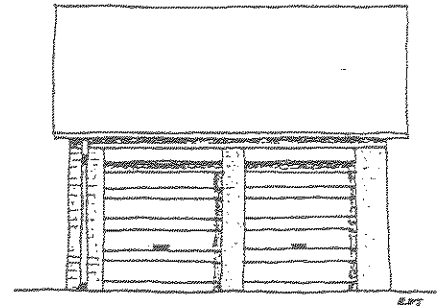

Not-Acceptable

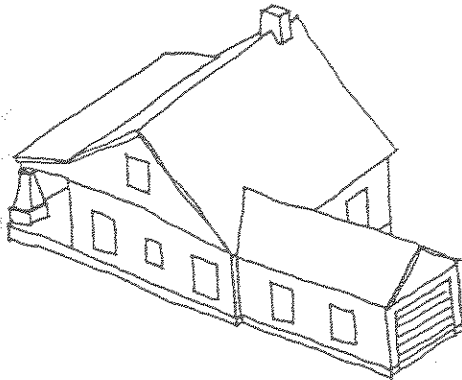

Appropriate

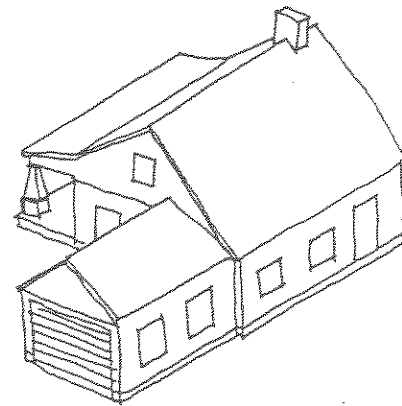

Not-Appropriate

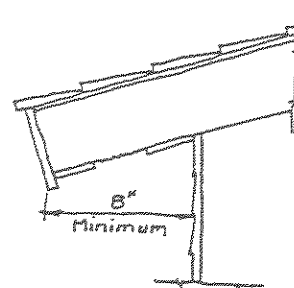
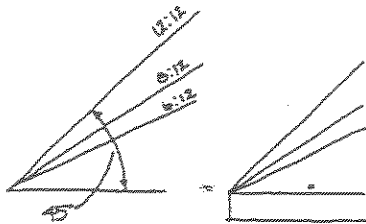

Appropriate roof slopes and eave overhang width for new construction.

23. PAINT AND PAINT COLORS

Although paint colors do not require approval, general rules of thumb to consider are to keep colors in keeping with the building's style and period of construction; avoid loud, garish, or harsh colors and bright hues; avoid too many colors on a building; and select where to highlight architectural details based on historic tradition for the building's type and style. Select a high quality oil based or exterior latex paint and expect to have to paint every eight to fifteen years depending on sunlight exposure, regular gutter and downspout maintenance, and wood surface condition.

- A. do not require review and approval by the Historic Zoning Commission.
- B. should be of high quality to provide the longest lasting finish possible.
- C. for Queen Anne and Folk Victorian period dwellings are recommended to be in keeping with traditional paint colors. Rich colors such as reds, browns, and greens were popular for these dwellings until the early 20th century. After 1900 tastes generally favored lighter colors such as tan, white, yellow, and light grey. Craftsman/Bungalow dwellings were often stained rather than painted although few examples of a stained exterior are found in St. Elmo. Paint colors appropriate for these dwellings include earth tones such as tans, browns, dark green, light and dark greys,
- D. should be kept to no more than three colors per building. The simpler the architectural style of the building, the simpler the paint colors.
- E. should be darker for the body of the house and lighter for window trim, door trim, and accents such as porches and eave brackets.

24. PARKING AREAS

The layout and design of St. Elmo took place prior to the invention of the automobile. Streets were laid out with rear alleys to access horses and horse drawn vehicles. Barns and sheds to house horses and vehicles were generally located directly adjacent to these alleys. With the rising popularity of the automobile many of these barns and shed were converted to garages or were replaced with modern garages in the early 20th century. In much of St. Elmo the primary automobile access to dwellings is via the rear alley. Some property owners also added side yard driveways for automobile access. In keeping with this tradition, parking areas and parking lots in the district should be sited at the side or rear of buildings.

- A. should not be located in front yards of houses.
- B. should preferably be of gravel or smooth concrete rather than black asphalt, aggregate, or brick.
- C. should be screened through plantings of hedges, shrubs, trees, or fences at edges and in medians within.
- D. for commercially-used houses, churches, apartment buildings, or schools should be located in rear yards if possible, but when necessary in a side yard, should be located no closer than the front wall of the structure.
- E. on vacant lots between buildings should align edge screening with front facades of adjacent buildings.
- F. on corner lots should have edge screening on both the primary and secondary street.

25. PORCHES, PORCH COLUMNS AND RAILINGS

Porches are one of the most important defining characteristics of a pre-1945 building. Original porches should be repaired and maintained. Those on the fronts of buildings should not be enclosed with wood or glass panels. The screening of porches on the fronts of buildings is appropriate. If replacement of porch elements is required, use materials to closely match those which exist. If the original porch is missing, construct a new porch based upon photographic or physical evidence, or base the design upon historic porches of district buildings built at the same period and in a similar architectural style. In some cases turn of the century dwellings had their original porches removed and replaced with Craftsman/Bungalow style porches in the 1920s and 1930s. If desired, these Craftsman/Bungalow porches may be replaced with porches in keeping with the original design.

- A. on front and side facades should be maintained in their original configuration and with original materials and detailing.
- B. should not be removed if original.
- C. and their details should be retained intact with repair work and replacement of missing parts, such as columns, posts, railings, balusters, decorative molding and trimwork, to match the original in design, materials, scale, and placement.
- D. on the fronts of dwellings should not be enclosed.
- E. on the rear and sides of dwellings may be enclosed when not readily visible from the street and if the height and shape of the porch roof is maintained.
- F. should have wood steps, not brick or concrete, for buildings with wood porch floors. Although not as appropriate, brick or pre-cast concrete steps may be added to front porches.
- G. may be screened if the structural framework for the screen panels is minimal and the open appearance of the porch is maintained. Wood framing for the screen panels is preferred, however, anodized or baked enamel aluminum frames are also acceptable. The use of "raw" or silver aluminum framing is not appropriate.
- H. on the fronts of dwellings may be partially enclosed with lattice panels for privacy. This should not exceed more than one-third of the porch area in order to maintain its traditional open appearance. Lattice panels should be added behind, not in front, of porch columns and railings.
- I. trellises of wood for plants are appropriate for front porches.
- J. should have wood tongue and groove flooring running perpendicular to the facade (unless the original floor is concrete).
- K. should not have brick floors or steps.

Historic porch columns and railings should be retained and repaired with materials to match the original. If the original porch columns and railings are missing, replacement porch columns and railings should be appropriate for the dwelling's architectural style and period.

- A. should be preserved and maintained. If repair is required, use materials to match the original in dimensions and detailing.
- B. often deteriorate first at the bottom next to the porch floor. If this is the case, consider sawing off the deteriorated area and replacing this section rather than replacing the entire column.
- C. of aluminum, wrought iron, or other modern materials are not appropriate for front porches. These types of columns are not preferred but are acceptable for porches at the rear of a dwelling or for side porches which are not readily visible from the street.
- D. on front porches should be rebuilt in historic designs if the original columns and railings are missing. For Queen Anne and Folk Victorian styles of the turn of the century, milled porch columns are appropriate and are readily available from wholesale companies. These porch columns are generally 8' in height and have widths and depths of 4". For Craftsman/Bungalow porches round, square, or tapered square wood columns are best. Although generally not available at wholesale hardware stores, they can be ordered from milling companies. These columns should fit the porch height and if round, have diameters of no less than 6" and no more than 10". Square columns or tapered square columns should be a minimum of 8" and a maximum of 10" in depth and width.
- E. on front porches may require new newel posts. Porch newel posts in historic designs are readily available and are generally 4' high and measure 4" in width and depth. The "ball top" newel post is best for Queen Anne or Folk Victorian porches. The "V-Groove" post is acceptable for Queen Anne, Folk Victorian, and Craftsman/Bungalow dwellings. Avoid the "French Gothic" post which is not as appropriate for the houses in St. Elmo.
- F. on front porches may require new balusters for the railing. Porch balusters (also called spindles) are readily available in historic designs from wholesale hardware stores. The milled spindles measuring 3' high and 2" in diameter are best for Queen Anne and Folk Victorian dwellings. Square balusters which are 3' high and 2" in width and depth are best for Craftsman/Bungalow dwellings. The "jumbo" balusters or spindles which measure 3"x 3" or 4" x 4" are too large and should not be added to front porches or porches readily visible from the street.

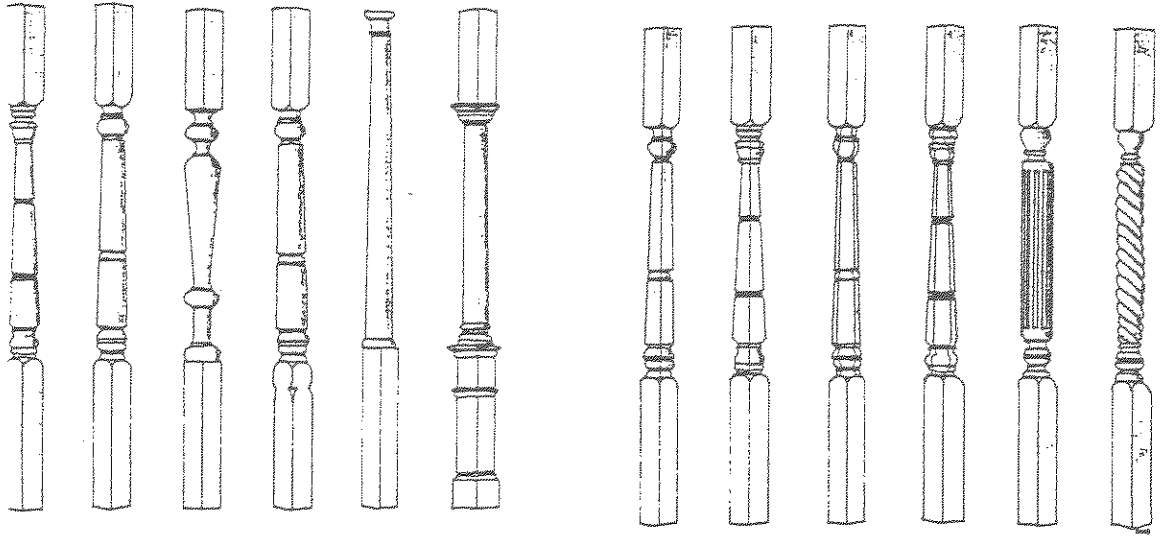

Typical milled porch columns dating to the Victorian era.

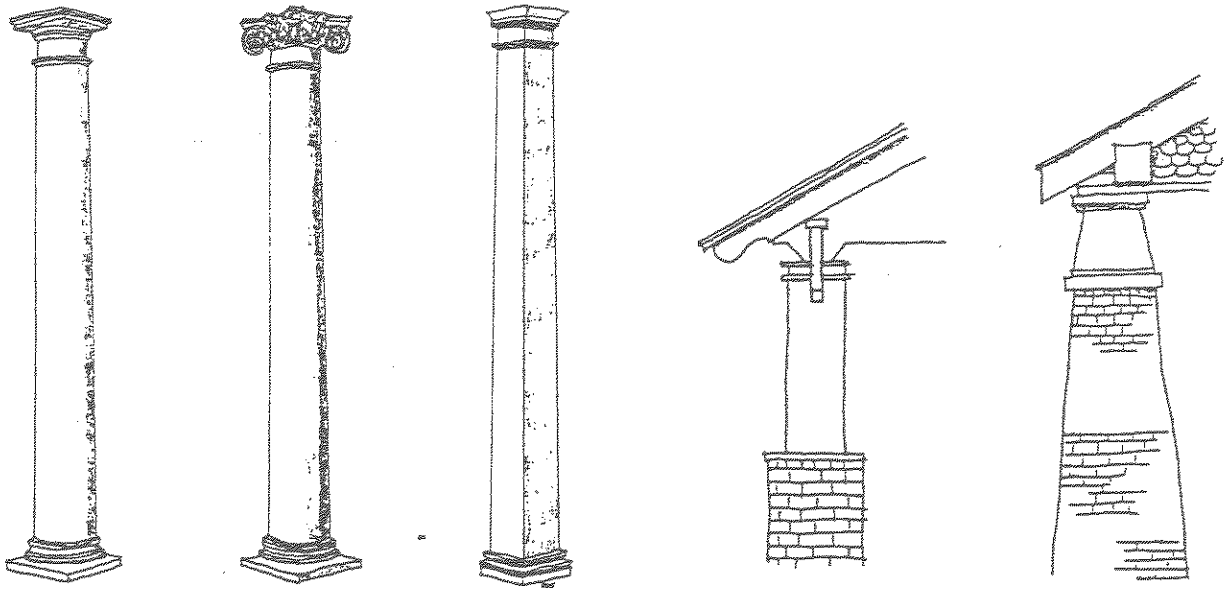

Classical-style porch columns.

Craftsman-style porch columns.

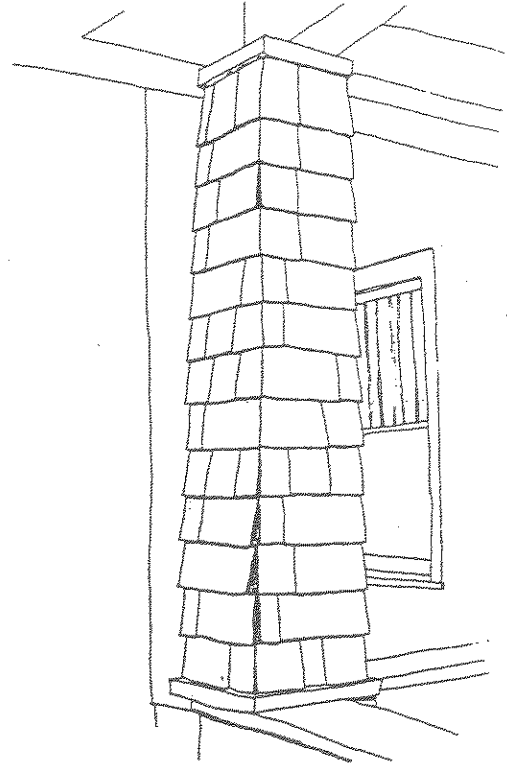
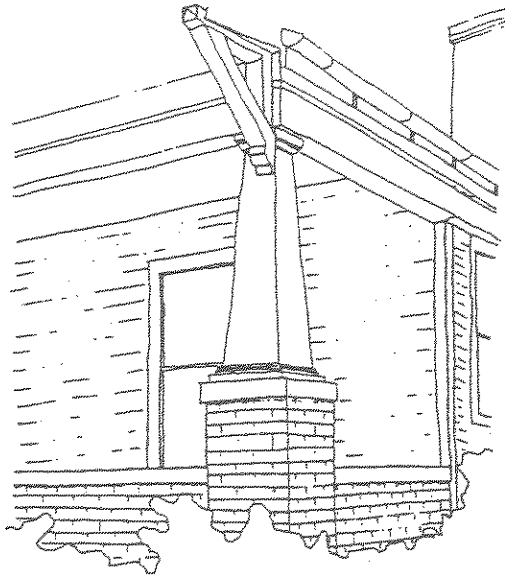

Craftsman-style porch columns at 4401 and 4102 Alabama Avenue.

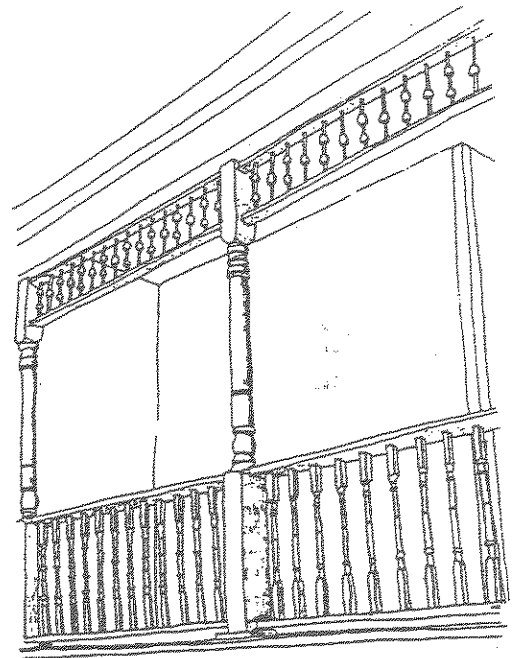
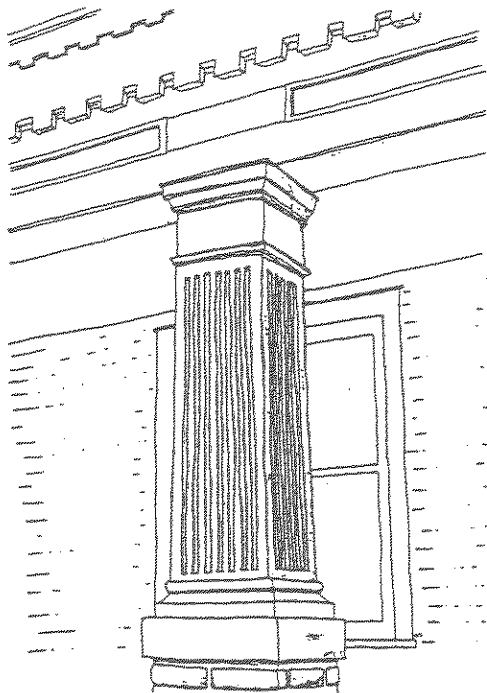

Fluted porch column (4703 Florida Ave.) and Victorian porch railing, columns and friezework (4521 St. Elmo Ave.).

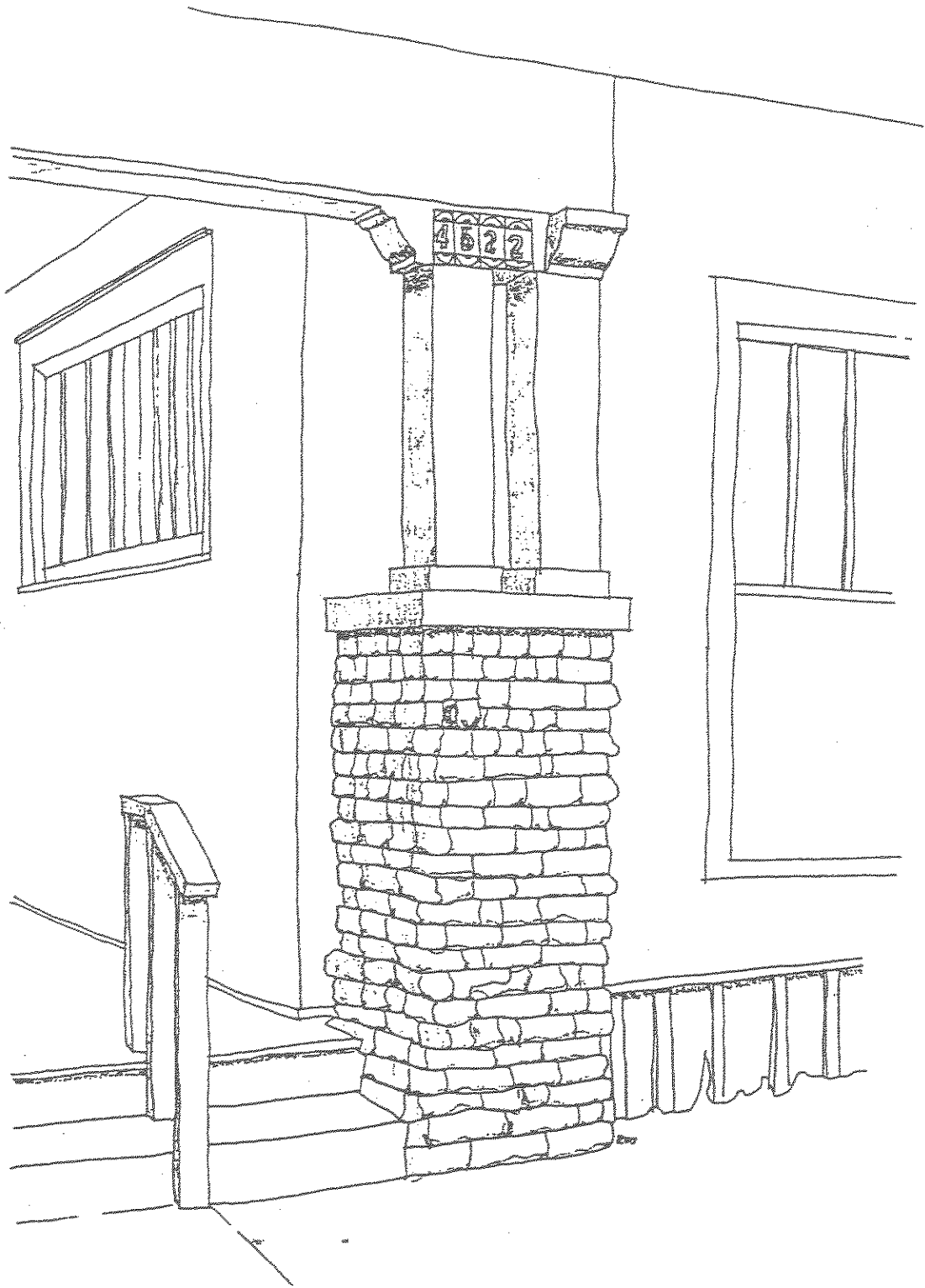

Craftsman style porch column on a rusticated brick pedestal (4522 Alabama Ave.).

26. RETAINING WALLS

Retaining walls are one of the primary characteristics of the streetscapes in the St. Elmo Historic District. The quality and variety of masonry materials and designs along St. Elmo, Tennessee, and Alabama Avenues is particularly notable. The preservation and maintenance of these retaining walls is recommended.

- A. of stone, brick, or concrete that are original to the structure (or built before 1945) should be preserved and maintained.
- B. built prior to 1945 should not be removed or replaced with new materials.
- C. which are deteriorating should be rebuilt using original materials or materials which match the original as closely as possible.

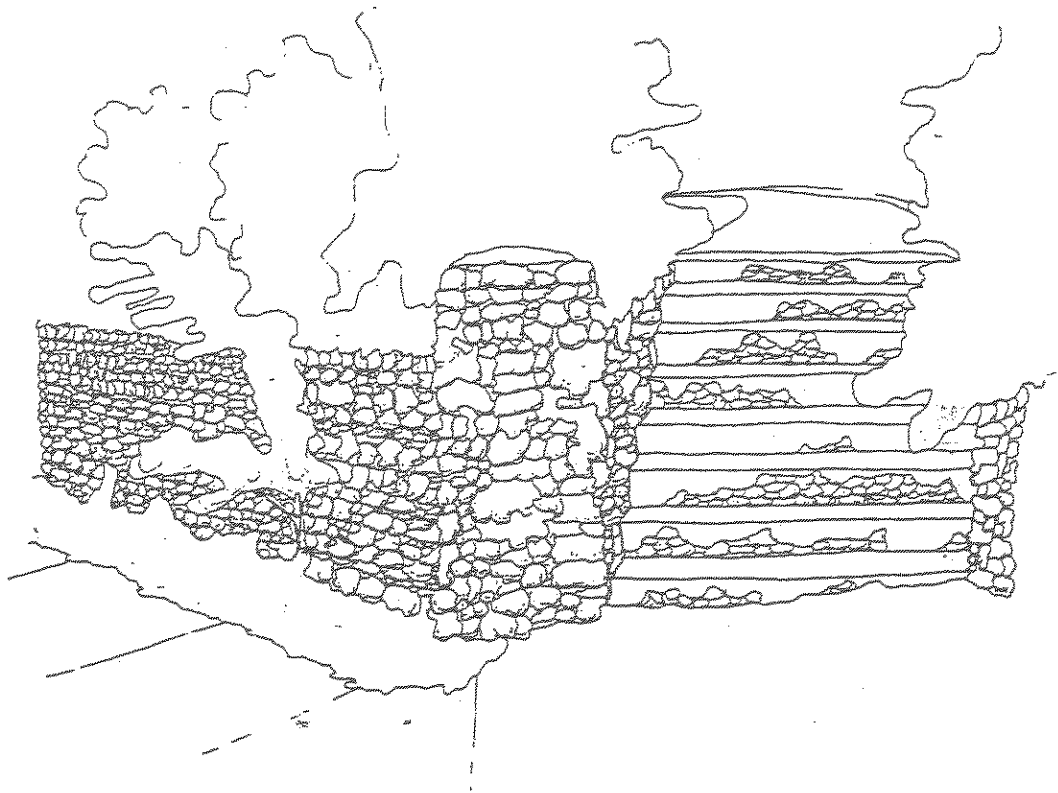

A stone retaining wall and steps at 4101 Alabama Avenue.

27. Roofs

Original roof forms should be preserved and maintained. If additions to roofs are desired such as new dormers or skylights, these should be added at rear or side rooflines which are not readily visible from the street. Historic roof materials such as clay tiles or slate should be repaired and preserved. If repair is no longer practical, replacement with asphalt, fiberglass or metal material is appropriate.

- A. should be preserved in their original size, shape and pitch, with original features (such as cresting, chimneys, finials, cupolas, etc.), and, if possible, with original roof material.
- B. may be re-roofed with fiberglass shingles if the use of the original material is not economically feasible (color should be dark gray, black, brown or shades of dark red; red or green may also be appropriate for Craftsman Bungalow period dwellings).
- C. should not have new dormers introduced on front facades but may have dormers added on rear facades or secondary facades where not noticeably visible if in keeping with the character and scale of the structure.
- D. should not have skylights, decks, or balconies added where readily visible from the street.

Metal Roofing was widely used in the 19th and early 20th centuries-it was lighter than slate or tile, it offered more fire protection than wood and most metals were less expensive than slate or tile. Many architects say its use helps contemporary designs appear more compatible with historic neighboring structures. Asphalt shingles became popular in the 20th century. Asphalt was more flame resistant than wood and had a cost advantage over other materials

Metal roofs are appropriate on primary structures as well as secondary buildings (garages, outbuildings). Each roof will be reviewed on a case by case basis, based on the style of the house. **Corrugated is unacceptable**

A. Materials

1. Minimum Gauge 26
2. Minimum Rib Width 12" (pan)
3. Maximum Rib Height 1"
4. Metal Shingle

B. Material Finish

1. Metal roofs shall have smooth, non-reflective finish
2. Muted colors appropriate to the architectural style of the structure
3. Galvalume is an acceptable color

Submittal of a sample is required prior to review

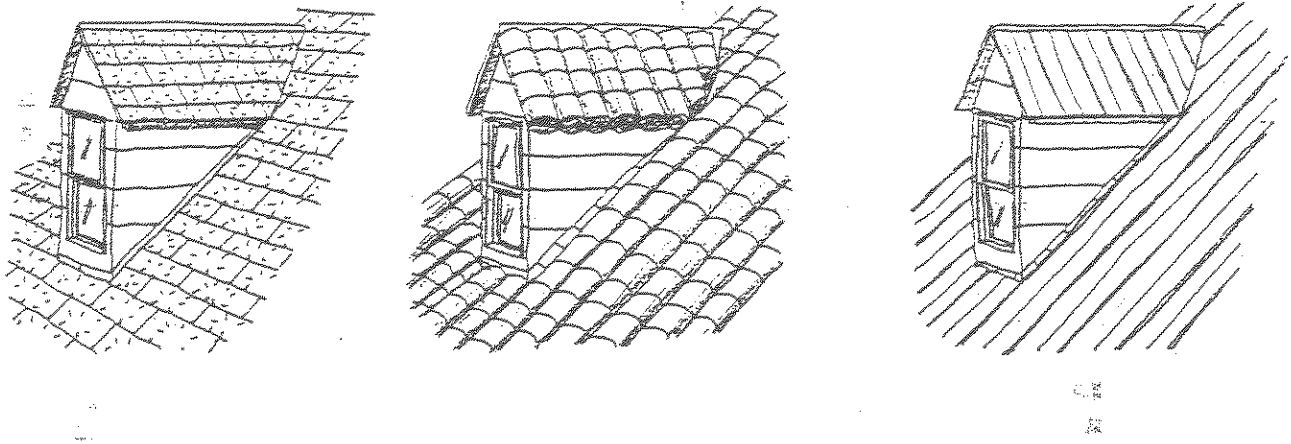

Pressed tin shingles, clay tile and standing seam metal roofs should be maintained as long as possible.

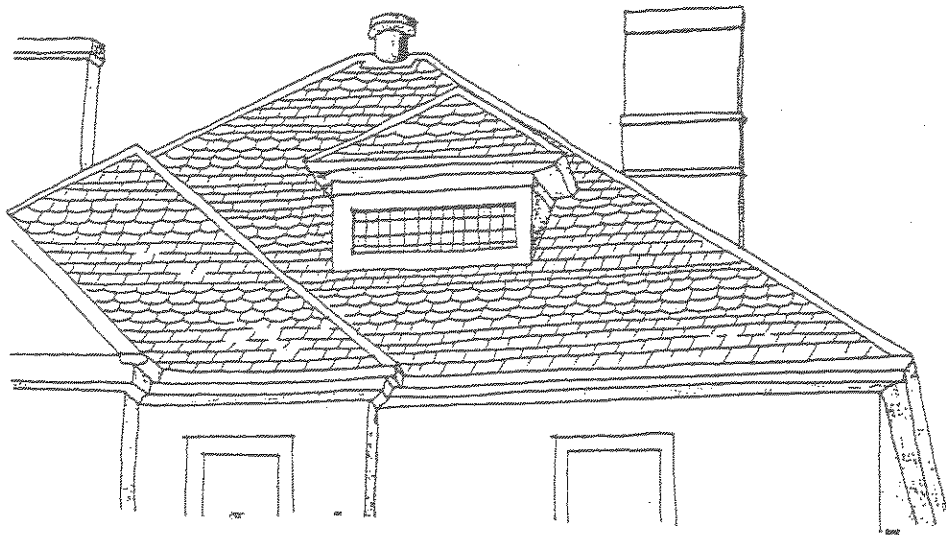

Historic roofing materials such as slate should be preserved and maintained (4411 St. Elmo).

28. SATELLITE DISHES

The use of satellite dishes for television reception is increasing in popularity. Traditionally, the C-Band dishes have been ten to eleven feet in span but in recent years the smaller seven and one-half foot dishes have become more commonplace. Also popular are the 18" DBS satellite dishes which are much smaller and size and easier to mount than the larger dishes. Satellite dishes may be installed in the district if they are sited in rear yards or along side yards which are not readily visible from the street. As non-historic features, the smaller dishes are preferred to the larger dishes.

- A. should never be installed in front yards or where readily visible in side yards.
- B. in the smaller sizes are more appropriate than the large, full view dishes.
- C. should be mounted as low to the ground as possible and the use of lattice panels, fencing or landscaping to screen the dish from view is recommended.

29. SCREENS

Screen panels for porches and screen doors for entrances are appropriate if the structural framework is kept to a minimum to retain the open appearance of the porch and the visibility of the historic door behind the screen door.

- A. may be added to porches if the structural framework for the screen panels is minimal, and the open appearance of the porch is maintained, and the panels are situated behind porch columns, posts, and railings.
- B. screen doors should be preserved and maintained if original.
- C. screen doors if new, should be wood and full-view or with structural members aligned with those of the original door.
- D. screen windows should be wood or baked-on or anodized aluminum and fit within the window frames, not overlap the frames.

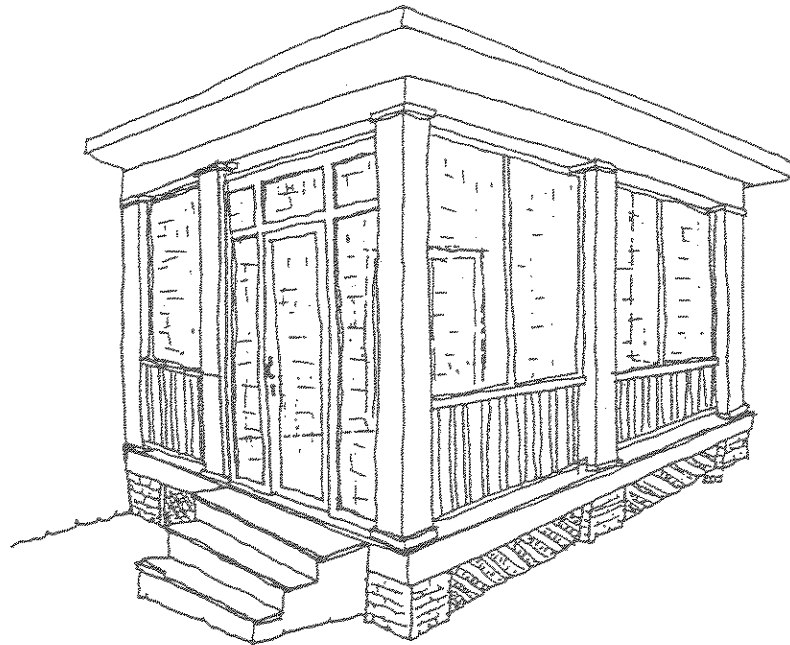

The screening of porches is acceptable as long as the translucent appearance of the porch is maintained.

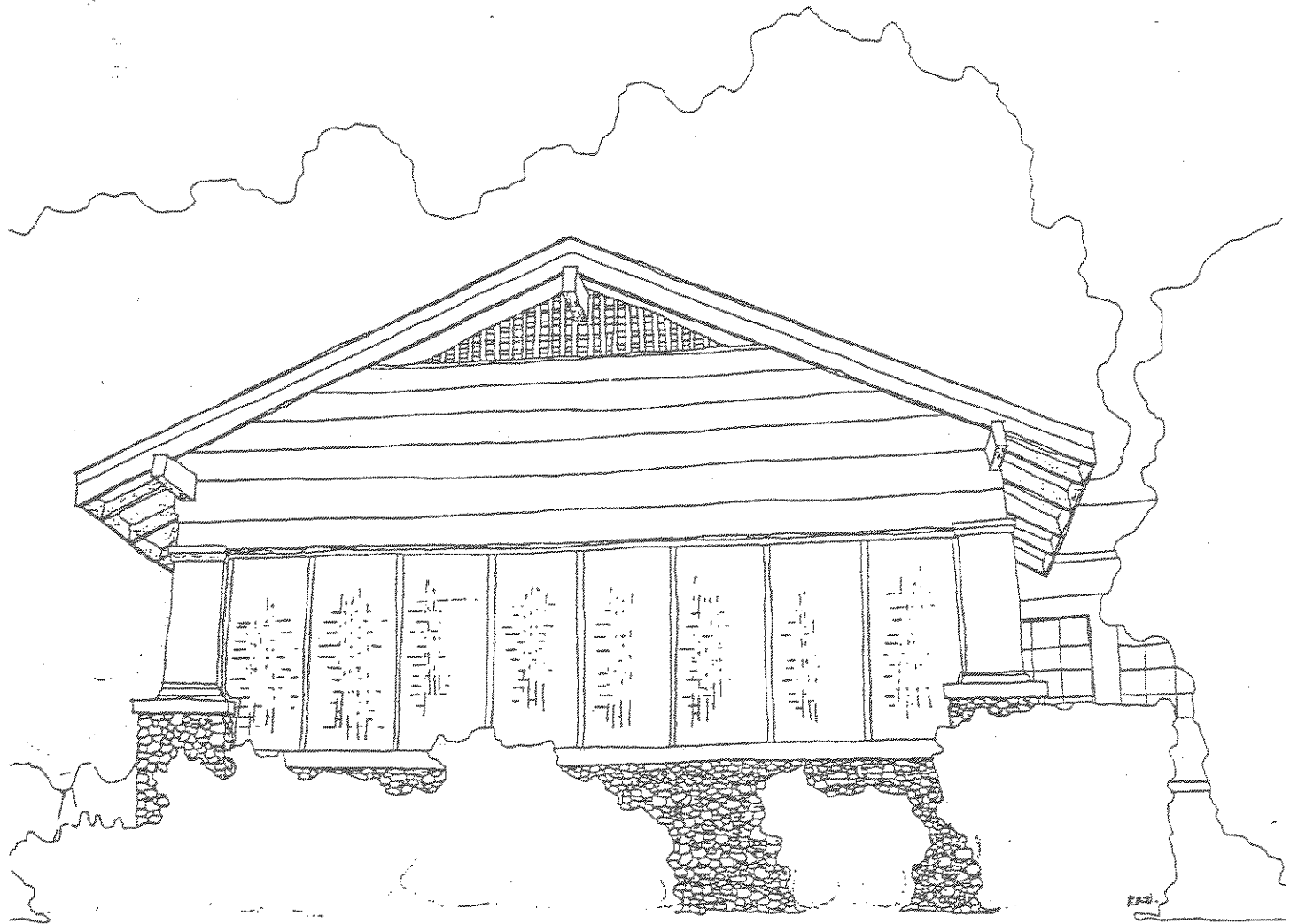

Appropriate screening on a Bungalow porch at 4616 Tennessee Avenue.

30. SECURITY DOORS AND WINDOWS

The installation of security doors and windows is appropriate within some parameters. Statistically, intruders primarily enter through rear or side doors or windows which are not readily visible from the street. The installation of security doors and window bars on these facades is appropriate. Although less appropriate on main facades, security doors may be installed if they are full view design or have minimal structural framing which allow the viewing of the historic door behind it. Ornate security doors with extensive grillwork or decorative detailing are not appropriate for entrances on the primary facade. Window bars on primary facades should also be as visually unobtrusive as possible.

- A. are not appropriate for primary facades but are for rear and side facades not readily visible from the street.
- B. security doors should be full-view, without ornate or decorative grillwork.
- C. security bars on windows should not be located on windows visible from the street.

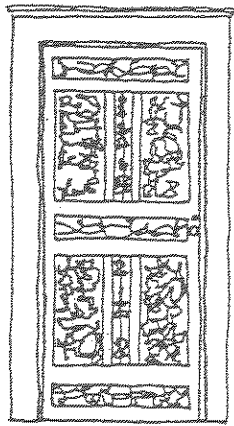

Inappropriate

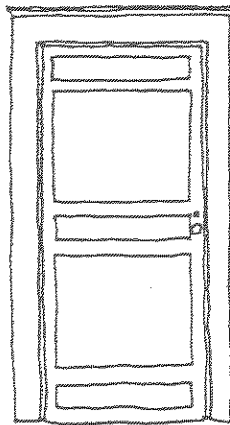

Better

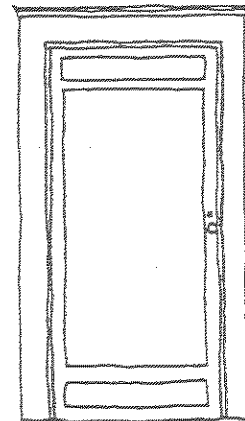

Better

Appropriate security doors should not feature decorative metal designs.

31. SHUTTERS

Window shutters were common on houses built at the turn of the century. Shutters had practical uses to block the sun in the summer and to protect windows during storms. With the widespread use of air conditioning in the mid-20th century, window shutters became more ornamental than practical and many original shutters have been removed. Most ornamental shutters available today are not appropriately sized or of the right materials. The addition of new shutters should only be of wood and with dimensions which match the window opening.

- A. which are original to the dwelling should be preserved and maintained.
- B. should not be added unless the building originally had them, the shutters are of louvered wood construction, and the shutters will fit the window opening (so that if closed, they would cover the window opening).
- C. of vinyl construction are not appropriate. These shutters generally have exaggerated wood graining which is not convincing and compatible with historic dwellings.

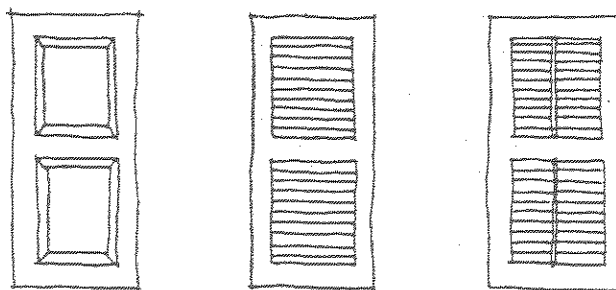

Acceptable

Better

Best

Appropriate replacement shutters.

No - Oversized shutter.

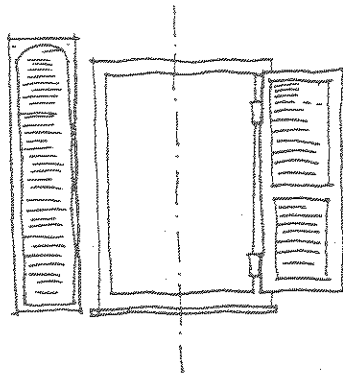

Appropriate shutter.

No - Inappropriate shutter.

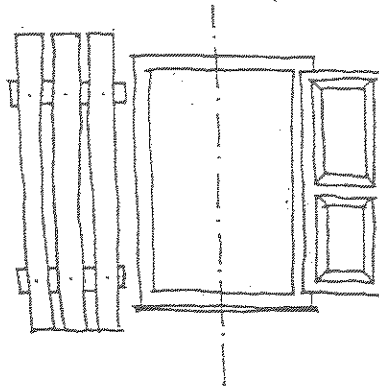

Appropriate shutter.

No - Shutter does not fit opening.

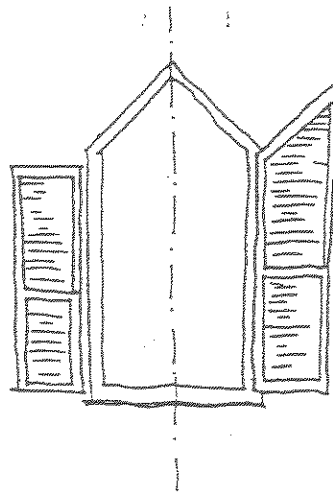

Appropriate shutter.

32. SIDEWALKS AND WALKWAYS

Sidewalks and walkways in St. Elmo are primarily of concrete construction. Many of these were poured in the 1910s and 1920s are still in good condition today. The use of concrete is traditional and appropriate in St. Elmo and the repair, replacement and addition of concrete sidewalks and walkways is recommended. The use of materials such as brick pavers, aggregate, and asphalt for sidewalks and walkways are not as appropriate as concrete.

- A. that are original to the property or district should be preserved.
- B. that are newly introduced on a property should be smooth concrete in patterns, dimensions, colors, and placement like original or early sidewalks in the district.
- C. of brick pavers, aggregate or pebble-surfaced, or asphalt are less appropriate for the district.

33. SIDING

Exterior wood siding and shingles are essential components defining a building's architectural character. The concealment of original wood siding with vinyl, aluminum, or other synthetic sidings is not appropriate. These siding materials do not successfully imitate the original wood siding dimensions or texture. There are also potential structural problems inherent in the use of these materials on historic buildings. Finally, these materials may not be cost effective compared to continued maintenance and painting of the wood siding. Because the issues surrounding the use of these materials is a major concern in St. Elmo, lets look at these issues more closely.

My house requires painting every five to ten years. Won't putting on vinyl or aluminum siding save me money?

Maybe in the short run but maybe not in the long run. No studies have been identified which can definitely say yes or no to whether these siding materials are economical. Its certainly not going to pay you back when you sell your house though. *Remodeling Magazine* recently looked at the most popular remodeling jobs and how much money is lost at resale. In other words if you invest \$1,000 in a remodeling job, will you get your \$1,000 back when you sell your house? The magazine figured that property owners would only get back two out of every three dollars for your typical aluminum siding job. In other words a third of your investment in aluminum siding would be lost when you sold your house.

Won't it save on energy costs?

Not really. For one- and two-story frame dwellings in Chattanooga's climate very little heat loss is through the walls. Most heat loss is through the roof, basement, windows, or doors. Any savings on energy costs after applying vinyl or aluminum siding will be hardly noticed.

Won't I never have to paint my house again?

You may not have to paint the wood again but you may have to eventually paint your vinyl or aluminum siding. All materials have a limited life span and we are now seeing property owners having to paint aluminum and vinyl siding which is 15 to 20 years old. The sale of paint for vinyl and aluminum siding has risen dramatically over the past few years due in part to these materials fading, chipping, or cracking. One of the recent flyers from a major company selling "maintenance free" vinyl siding states that "aluminum siding just doesn't stand the test of time. It dents, shows scratches and corrodes." Hey, wait a minute, didn't they say once that aluminum siding would last forever? The same claim they now make for viryl siding?

Putting vinyl or aluminum siding on my house won't hurt it right?

Not necessarily. Wood siding expands and contracts with the seasons and synthetic siding can trap moisture and condensation in the wood. This can lead to rotted siding and structural problems. Also, if you have a gutter or downspout problem and water runs down inside your walls, synthetic sidings can keep it hidden until major damage is done.

Okay, vinyl and aluminum siding isn't perfect but I still want to put it on my house. Is there a way to do it and still maintain the "historic" look of the house?

Like all remodeling projects there are good siding jobs and bad siding jobs. If you apply vinyl or aluminum siding make sure that historic features such as eave brackets, "gingerbread," and other details are not removed or concealed. Window and door surrounds should also not be concealed. Choose a siding which matches the original dimensions of the wood siding as closely as possible. Make sure that the siding is vented as much as possible to avoid condensation.

Siding guidelines for St. Elmo are as follows:

- A. wood siding original to the building should be repaired rather than replaced only where necessary due to deterioration.
- B. wall shingles original to the building should be preserved but if replacement is necessary the new shingles should match the original in size, placement, and design (this includes decorative wood shingles of Victorian buildings as well as wood or asphalt shingles of bungalow-period houses).
- C. the application of masonite over original wood siding is also not appropriate and is discouraged. Repair of original wood siding should be with wood siding to match the original. However, masonite may be used if the dimensions, texture, and color matches the original wood siding.
- D. the removal of synthetic sidings such as aluminum, asbestos, and vinyl and the restoration of the original wood siding is highly encouraged.
- E. the application of synthetic or substitute materials such as vinyl or aluminum over original wood siding is not appropriate and their use is discouraged but not prohibited. To be approved, the application of these materials must not result in the concealment of or removal of original decorative detailing or trim. This includes the concealment of window and door surrounds. Synthetic siding materials should match the dimensions of the original wood siding as closely as possible. Care should be taken to have the synthetic sidings vented to the maximum extent possible. NOTE: The application of synthetic sidings is in violation of federal standards and such projects would not qualify for any federal tax credits.

- F. consideration for determining the appropriateness of a change in siding will be based on the following criteria: what is the age of the building and is it contributing or significant to the district; where is the building located within the district, and; are the proposed changes visible from the street or on a primary facade?
- G. siding of particle board or pressboard is also not appropriate for the fronts of dwellings or sides which are readily visible from the street. Almost all frame dwellings in St. Elmo have horizontal siding forms and vertical siding such as "T1-11" are not appropriate.
- H. asbestos shingles which are original to a dwelling should be kept stained or painted. If asbestos shingle siding is deteriorated or poses a health hazard, it may be enclosed or covered with other synthetic sidings such as vinyl or masonite.

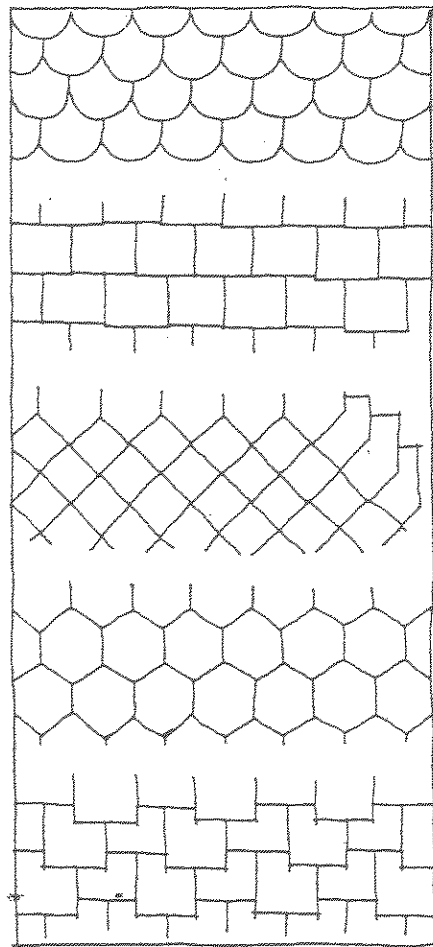

Fish Scale

Plain

Diamond

Hexagon

Staggered

Wood shingle variations found in St. Elmo.

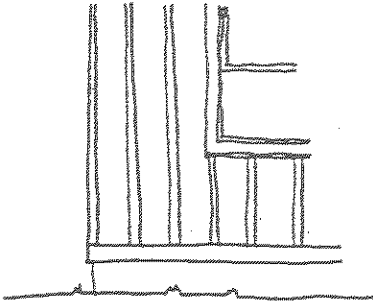

Vertical board panels.

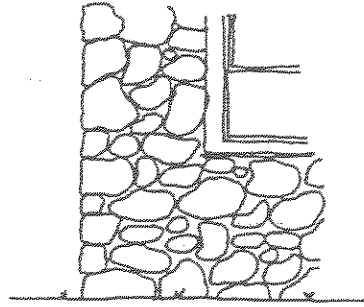

Stone veneer

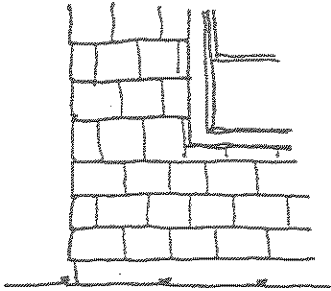

Wood shingle

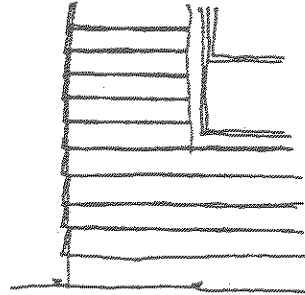

Aluminum

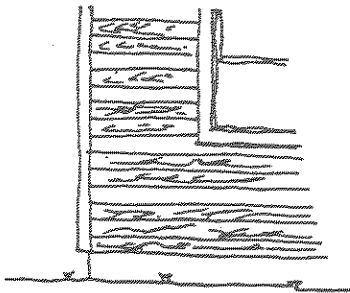

Vinyl

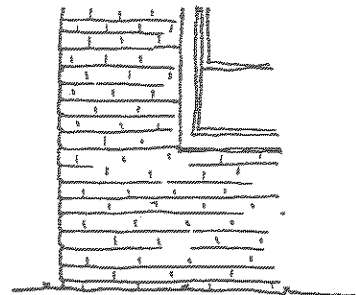

Brick veneer

Inappropriate replacement siding.



Historic siding should be preserved and maintained (1610 West 49th Street).

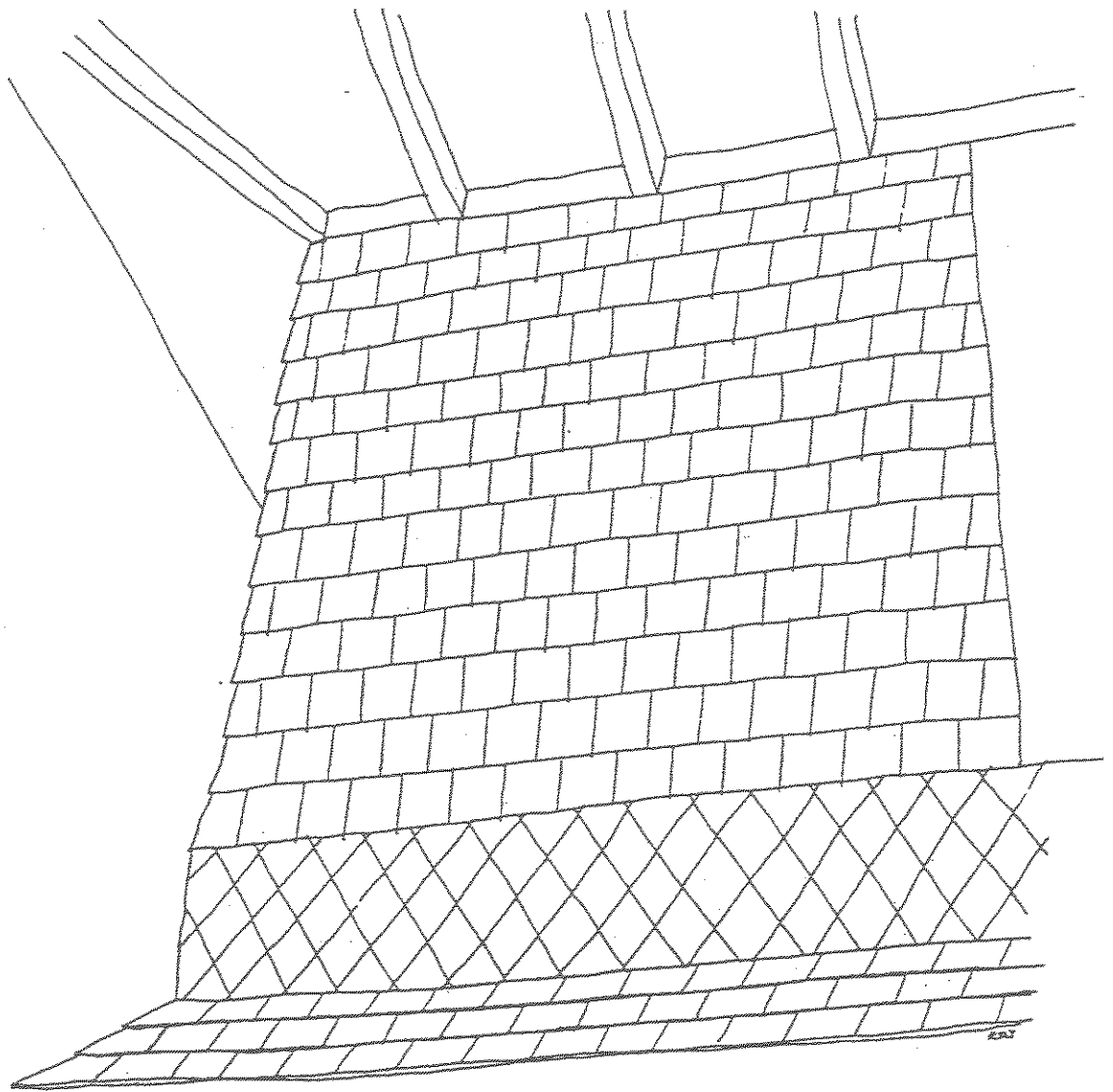

Original wood shingles located at 4512 Alabama Avenue.

34. SIGNS

St. Elmo is primarily a residential area and most signs are confined to corner commercial buildings and churches.

- A. should be kept to a minimum with preferably a maximum of two per commercial business or church.
- B. for churches may be freestanding or attached to the face of the building. For commercial buildings signs may be projecting, on windows, or affixed to the face of the building.
- C. should not cover or obscure architectural features.
- D. should not be illuminated with visible bulbs or luminous paints, but with remote sources.
- E. should be of traditional materials such as finished wood, glass, copper, or bronze, not plywood, plastic, or unfinished wood.
- F. should utilize logos or symbols for businesses.
- G. should have no more than three colors and use colors that coordinate with the building colors.
- H. for mounting on masonry walls should be anchored into the mortar, not the masonry.

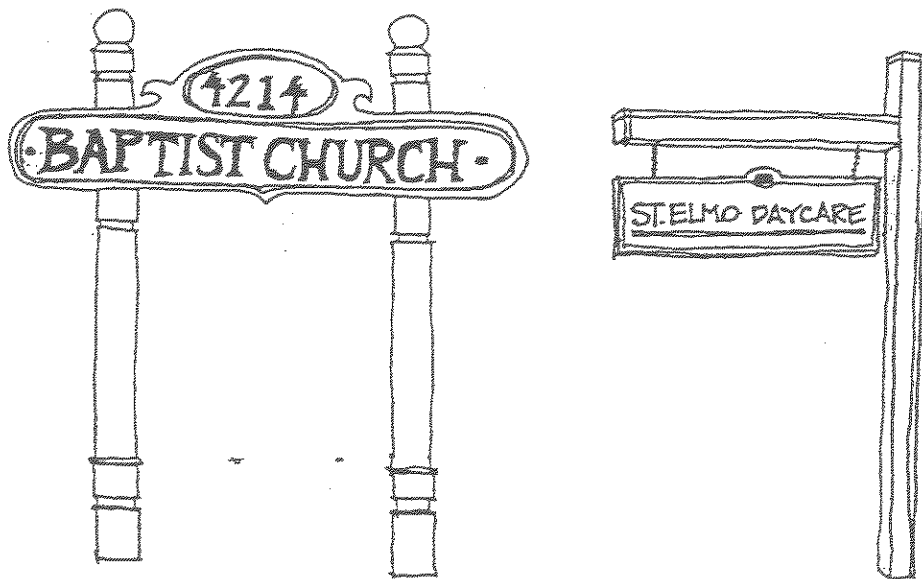

Examples of appropriate freestanding signs for the neighborhood.

35. SKYLIGHTS

The addition of skylights can make the use of upper floor space or attic space more practical. The installation of skylights is appropriate as long as they are placed on rear roof lines, behind gables or dormers, or otherwise not readily visible from the street. Skylights which are flush with the roofline or lay flat are more appropriate than those with convex or "bubble" designs.

- A. should not be added where visible from the street. Skylights should be placed at rear roof lines or behind gables and dormers.
- B. should be flat or flush with the roofline, not convex or "bubble" designs.

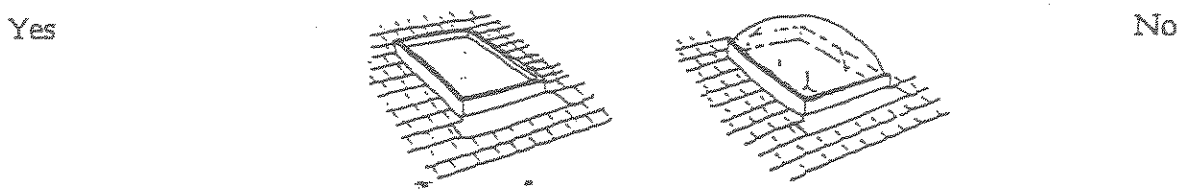
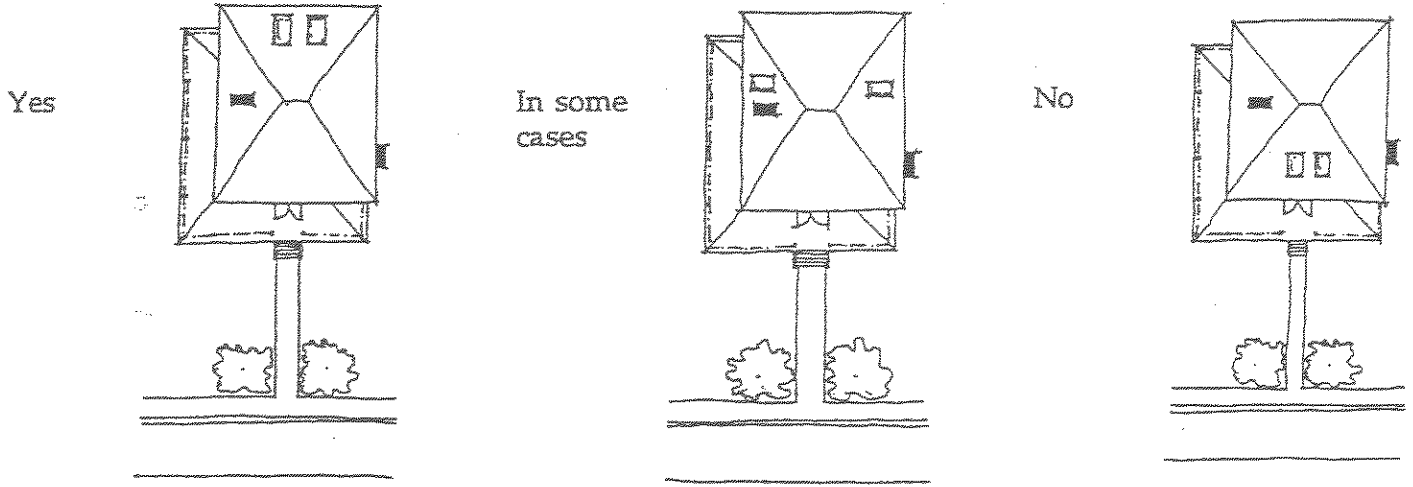

Skylights should be on the rear, not front, of the roof.

36. SOLAR COLLECTORS

Solar energy collectors or panels are available which can be both freestanding or attached directly to the building. Those on buildings are usually located at the roofline and consist of flat panels which absorb the sun's rays. Freestanding collectors are a series of pole-mounted panels sited next to the building. Solar collectors are appropriate as long as freestanding panels are sited in rear yards and the roof panels are on rear facades or side facades not readily visible from the street.

- A. and solar energy panels should be located on rear sections of the roof, behind dormers or gables or other areas not visible from the street.
- B. which are freestanding should be located at rear yards or on side facades not readily visible from the street. If side yard locations are readily visible (such as a corner lot), freestanding panels may be installed if they are effectively screened by fencing, lattice panels, or landscaping.

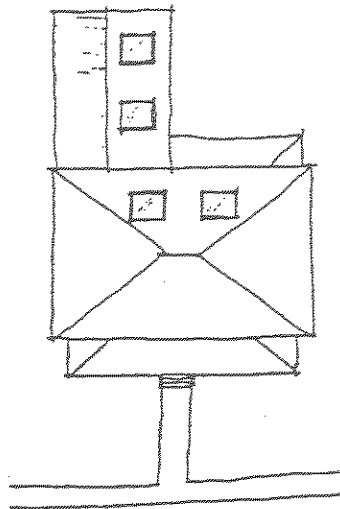

Solar collectors and panels should be sited on rear roofs.

37. STAIRCASES AND STEPS

Multi-family use of dwellings in St. Elmo can sometimes require the construction or replacement of exterior wall staircases to meet fire codes. If required, staircases should be placed on rear facades or side facades not readily visible from the street. Staircases should not be added on primary facades.

- A. should not be added to building exteriors where visible from the street. Rear or side facades are appropriate locations for exterior stairs, the fronts of buildings are not.
- B. should preferably be of wood construction. However, metal stairs are also acceptable especially those at the rear of buildings.

On most older dwellings wood steps were built leading to the front porch. On a few of the larger homes, brick or stone was also sometimes used in step construction. Steps of poured concrete were also common for Craftsman/Bungalow dwellings. Since steps are readily exposed to the sun and rain they require continual maintenance and repair. In many cases the original wood steps have been removed and replaced with steps of brick or concrete. Replacement of deteriorated wood steps with wood is preferable to replacement with brick, pre-cast concrete, or wrought iron.

- A. original to a property should be retained. Wood and concrete steps should be repaired with materials to match the original.
- B. to porches with wood floors should be replaced with wood rather than brick or concrete. The addition of brick, concrete, wrought iron steps for front porches of wood is discouraged but acceptable. If pre-cast concrete or wrought iron steps are used they should be painted to match the color of the porch.

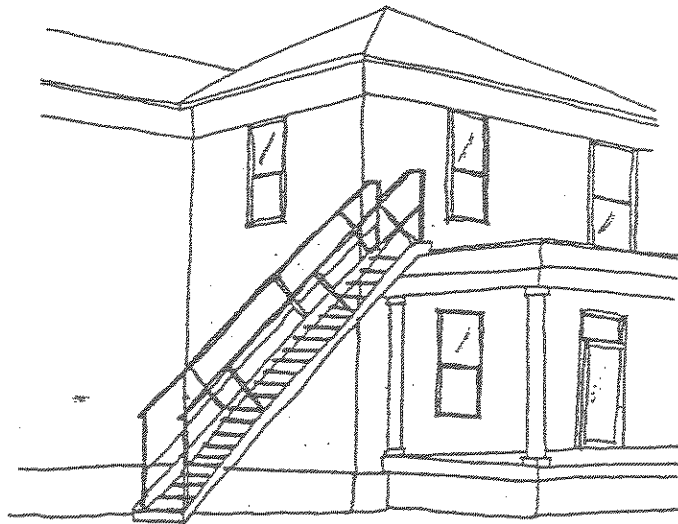

Exterior staircases should never be located on the front of a building.

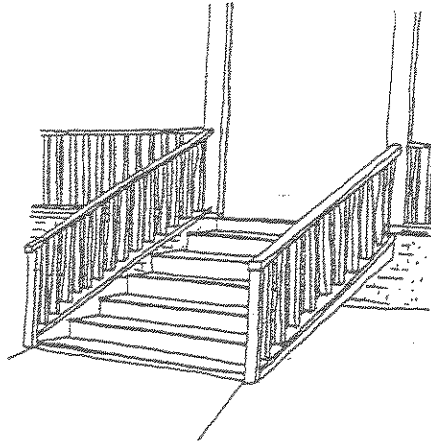

Wood steps are preferred.

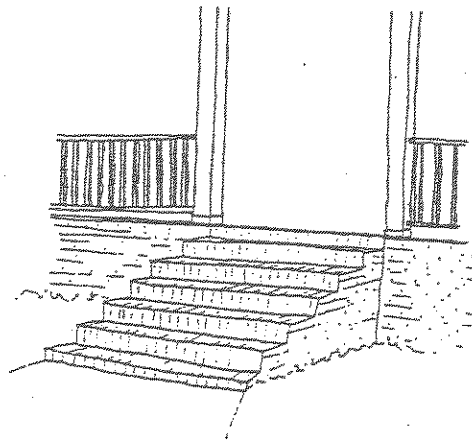

Brick steps are acceptable.

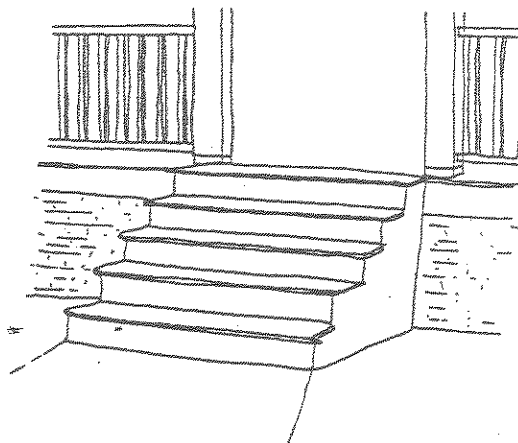

Concrete steps are to be avoided.

38. STORM WINDOWS AND DOORS

The installation of storm windows and doors can help in lowering energy costs and are appropriate for older dwellings. Storm windows should be full-view design or have the central meeting rail at the same location as the historic window behind it. Windows and doors of dark anodized aluminum or baked enamel are preferred to those of "raw" or shiny aluminum.

- A. storm doors should be of full-view design and of baked-on enamel or anodized aluminum in dark colors.
- B. storm windows should be baked-on enamel or anodized aluminum and fit within the window frames, not overlap the frames.
- C. storm windows should be full-view design or with the central meeting rail at the same location as the historic window.
- D. storm windows with built-in lower screen panels are appropriate.

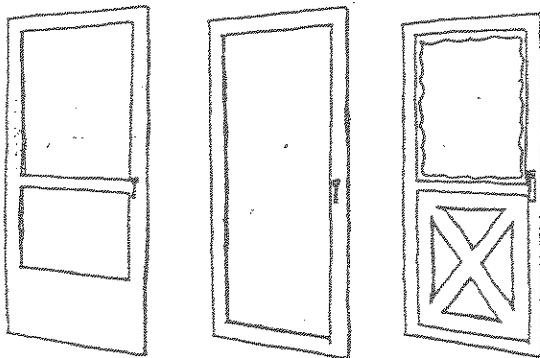

Acceptable Best Not-Acceptable

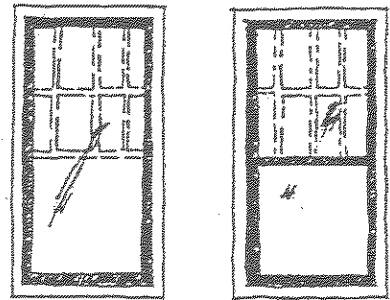

Acceptable Best

39. SWIMMING POOLS

The installation of swimming pools in rear yards is appropriate as long as they are fenced or screened in some manner.

- A. should be located in rear yards and screened from street view by fencing or landscaping.

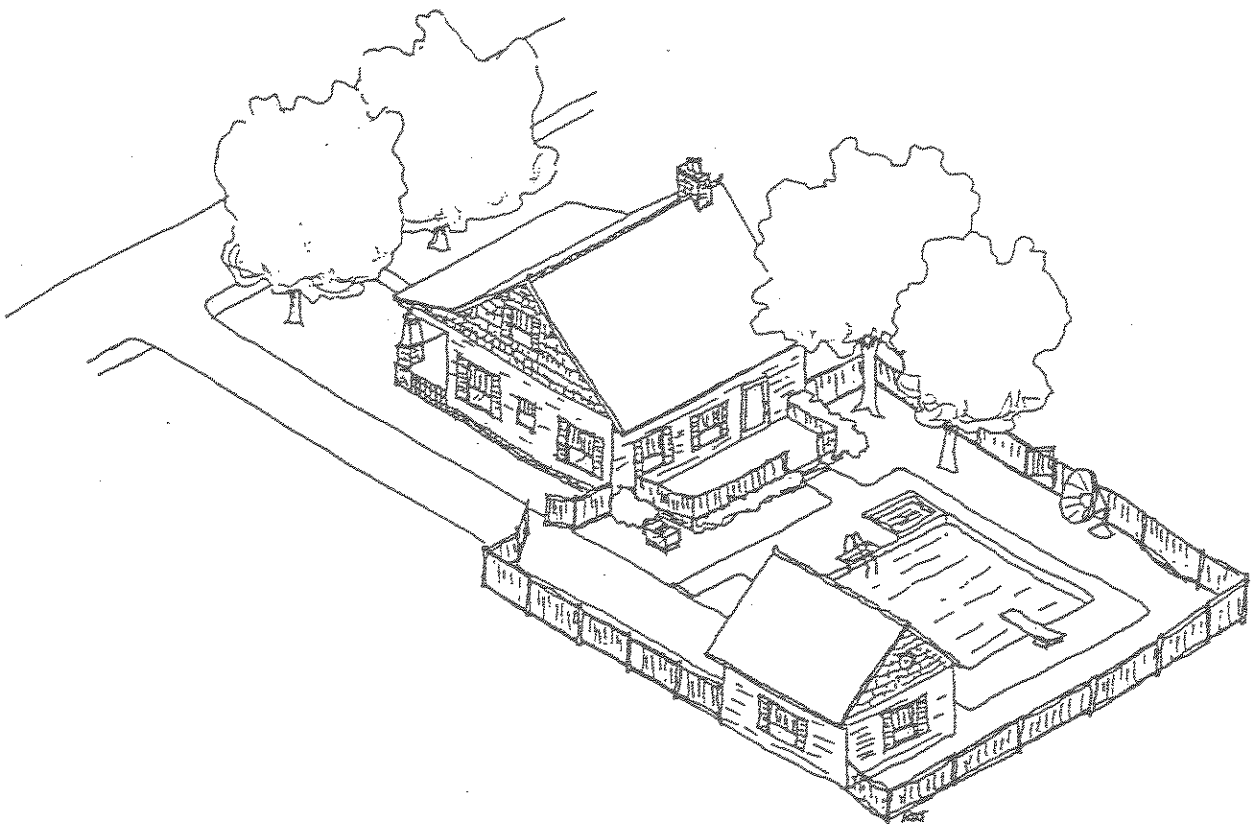

Appropriate swimming pool installation.

40. WOOD

Wood is the predominant material used for house construction in St. Elmo. Wood siding, decorative details, and trim should be preserved and maintained or repaired with materials and dimensions to match the original.

- A. original to the building should be repaired rather than replaced only where necessary due to deterioration.
- B. should be replaced only when necessary with wood features and details match the original in dimension, size, material, and profile.
- C. should be maintained through regular painting but when paint removal becomes necessary, it should be done by scraping, heat (heat guns and plates), or chemical methods, never through sandblasting or other abrasive methods.

41. WINDOWS

St. Elmo boasts a wide variety of historic wood windows in various sash designs and sizes. Windows should be maintained or repaired to match the original design. If windows are deteriorated beyond repair, the installation of new wood windows to match the original designs is best. Vinyl clad windows or windows of anodized aluminum are also acceptable but these are more appropriate at the rear or sides of dwellings which are not readily visible from the street. If only one or two windows on the front of the house are deteriorated, consider removing good condition windows from the rear or sides of the house to add in their place.

Original window openings should not be covered or concealed. They should also not be enclosed for the addition of smaller windows. New windows should not be added on the fronts of dwellings but may be added at the rear or sides if not readily visible from the street. The addition of window screens to historic windows is fine as long as the screens are full-view design or have a central meeting rail to match the historic window.

- A. should be preserved in their original location, size, and design and with their original materials and numbers of panes.
- B. should not be added to primary facades or to secondary facades where readily visible.
- C. should be repaired rather than replaced, but if replacement is necessary due to severe deterioration, the replacement should be in-kind to match the originals in material and design.
- D. of steel or other metal designs should be preserved and maintained, or replaced with new metal windows which are similar in appearance and materials.
- E. should not have snap-on or flush muntins. These muntins are much thinner than the muntins on historic windows and don't look real.
- F. screens and/or storms should be wood or baked-on or anodized aluminum and fit within the window frames, not overlap the frames.
- G. should not have shutters unless they are of louvered wood construction and are designed to fit the window opening (so that if closed, they would cover the window opening).
- H. should not have security bars where visible from the street.

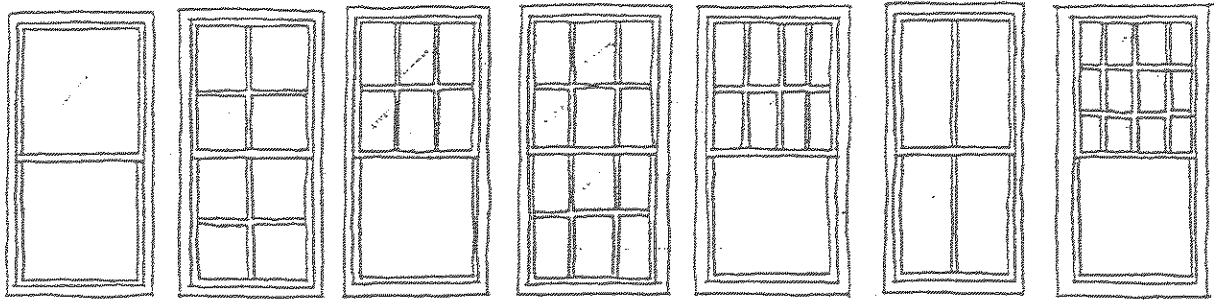

1/1

4/4

6/1

6/6

8/1

2/2

12/1

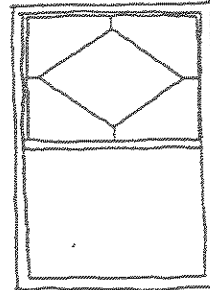
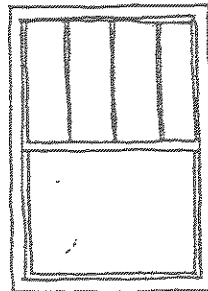
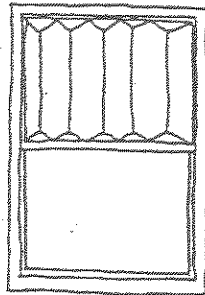

Diamond light sash

Vertical light sash

Craftsman light sash.

Common window designs in St. Elmo.

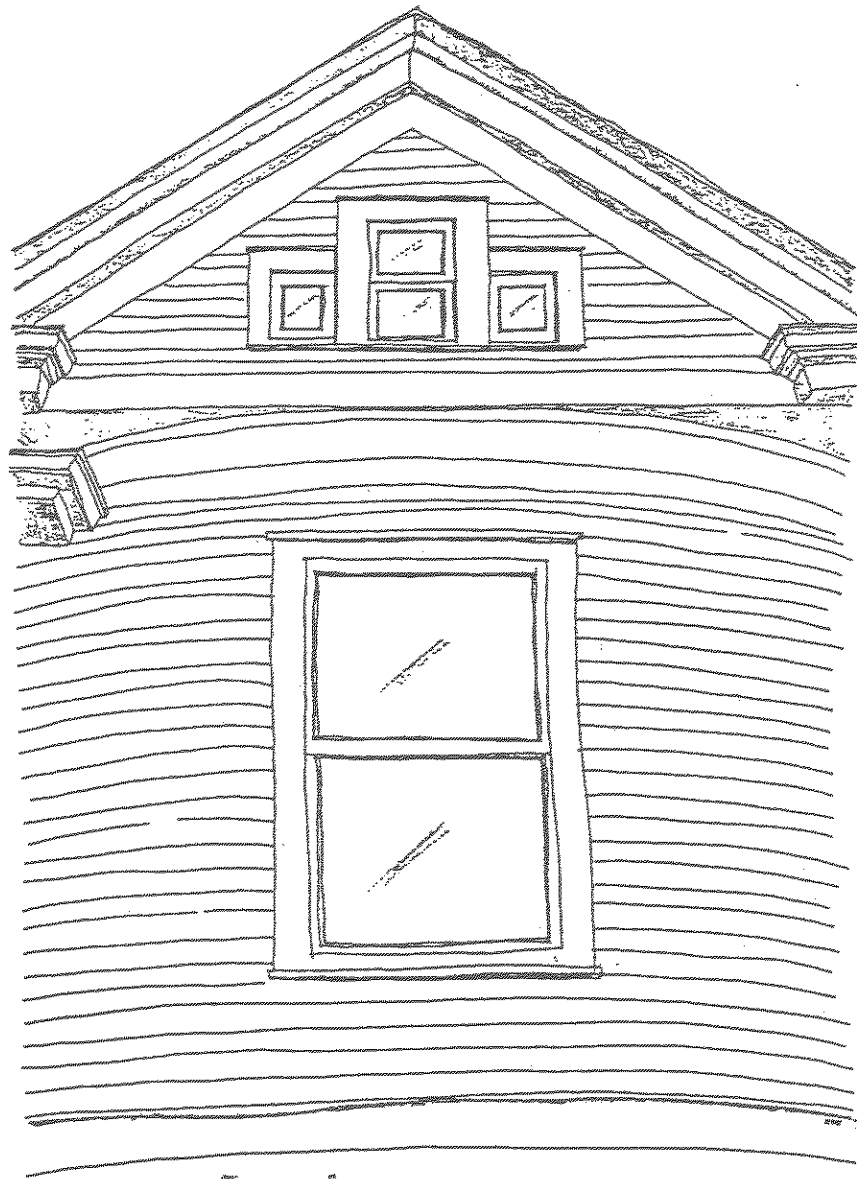

Historic windows should be preserved and maintained (4207 St. Elmo).

COMMERCIAL BUILDINGS

The commercial area of St. Elmo is not within the locally designated district and property owners are not required to go through the COA process. However, property owners are encouraged to follow these guidelines when work is undertaken.

UPPER FACADE COMPONENTS

Cornice or Parapet
Generally of corbelled brick.

Windows
Rectangular windows are most common in the St. Elmo commercial area although some also have arched windows.

STOREFRONT COMPONENTS

Beltcourse
Visual division between storefront and upper facade, a decorative cornice, decorative brickwork, or a place for signage.

Display Window(s)
Usually with bulkheads below and transoms above.

Entrances
Usually recessed in middle or at side.

Door(s)
Both single and double light doors are common.



42. STOREFRONTS - GENERAL APPROACH

Preserve (maintain or restore, not remove or alter) existing original storefronts. Storefronts are important to a commercial building's architectural design.

- A. Storefront features that have become deteriorated should be repaired rather than replaced.
- B. If replacement is necessary, new storefront elements should be with features to match the original in design and materials.
- C. Storefronts which were altered after 1945 should be reconstructed based upon pictorial or physical evidence of the original.
- D. If original storefront appearance is unknown, install a storefront based upon traditional designs. This should include the construction of bulkheads, display windows, and appropriate materials. New storefronts should be typical of those built during the late 19th and early 20th century and not reflect earlier or later architectural styles or periods.



Historic storefronts should be preserved (3904 St. Elmo).

43. ENTRANCES

Original entrances should be preserved, maintained or repaired in their entrance design, materials, and arrangement whether recessed or flush with the sidewalk.

- A. Historic doors should be retained and repaired with materials to match the original. Doors added to storefronts should be replaced with doors to match the original in design and materials. Solid wood doors should not be installed on storefronts.
- B. If the original door design is unknown, replace with plain wood doors in a single light (glass area) design, not solid paneled doors; decorative doors; or any kind of door based upon a different historical period or architectural style (Colonial, Gothic church doors etc.).
- C. New doors should generally use glass proportionate to display window glass and kickplate panels proportionate to bulkhead panels. Wood is the material most appropriate for new doors, however, metal with a dark or bronze anodized finish and with a wide stile may be substituted. Raw aluminum or other silver-colored metals are never appropriate.

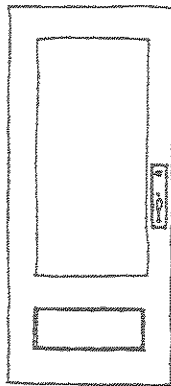

Original Door

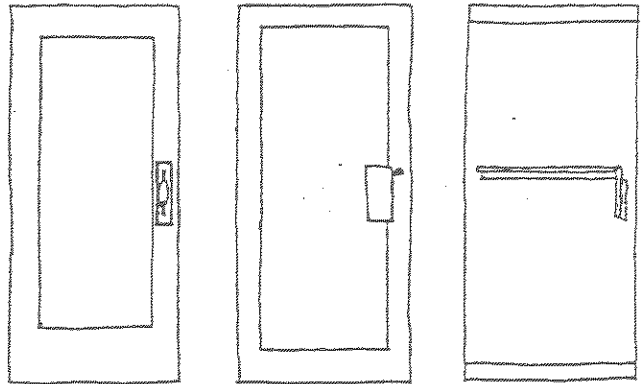

Appropriate replacement doors.



Historic entrances should be maintained (3907 St. Elmo).

44. DISPLAY WINDOWS AND BULKHEADS

Original display windows should be preserved, maintained, or repaired.

- A. New display windows should match the original in location, design, size, and materials.
- B. If the original display window design is unknown, replacement windows should be traditionally scaled with large glass lights and with as few structural divisions as possible to maintain the traditional transparent storefront look.
- C. Window mullions or framing should be of wood, copper, or bronze metal.
- D. Clear glass should be installed on storefronts, not tinted glass. Interior shades or blinds should be utilized for privacy.
- E. Transom lights should not be obscured.

Bulkheads, also known as kickplates, are the lower panels on which the display windows rest. Original bulkheads should be preserved, maintained, or repaired where they exist. Original bulkhead panels should not be altered or removed.

- A. When replacing missing bulkheads, the original should be matched in design, size, and materials.
- B. If the original bulkhead material is unknown, replacement may be of wood or brick which matches the original.



Display windows at 3907 St. Elmo Avenue.

45. WINDOWS

Most of the two-story commercial buildings in St. Elmo retain their original wood sash windows on the upper floor. Original window sash should be preserved, maintained, or repaired including their size, number and arrangement of lights, materials, and decorative detailing. Windows should not be concealed, enclosed or covered.

- A. Deteriorated windows should be repaired rather than replaced. Missing windows should be replaced with windows which match the original in size, number and arrangement of lights, and materials.
- B. If the original window configuration is unknown, rectangular one-over-one wood sash windows are most appropriate for St. Elmo commercial buildings. Wood is the preferable material for new windows. Anodized or bake-on enamel aluminum, in white or dark finishes is also appropriate.
- C. The application of flush or snap-on muntins is not appropriate. These materials do not replicate the appearance of historic windows.
- D. Shutters should not be added to windows on commercial buildings unless there is physical or pictorial evidence that they originally existed on the building. Wood shutters may be used to conceal blocked-in or bricked-in windows until restoration of windows takes place.
- E. Shutters should be of louvered wood design and sized to fit their opening. If closed they should completely cover the window opening.
- F. Original window surrounds and detailing should be maintained and preserved such as sheet metal hood molding, brick or stone lintels, and sills.
- G. Storm windows are appropriate for historic window openings if they are of full view (single light) design or if they match the dimensions of the upper and lower sash with matching meeting rails. "Raw" or unfinished aluminum storm windows are not appropriate. If aluminum windows are used they should have an anodized or baked-on enamel finish.



Original windows at 3915 St. Elmo Avenue.

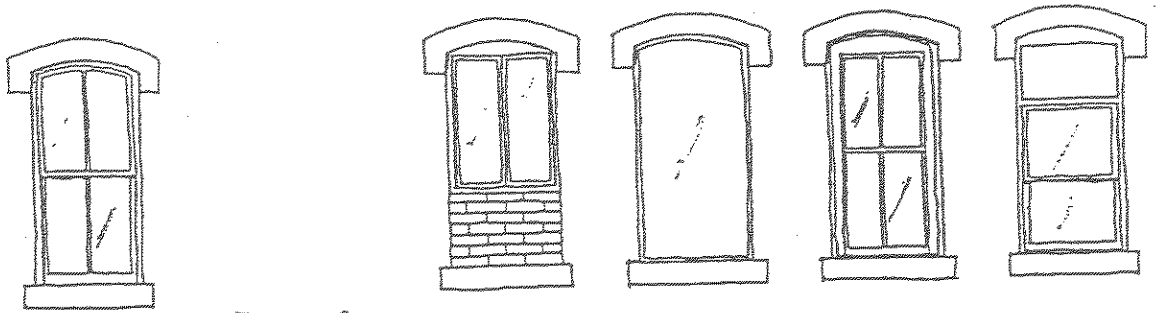

Original sash window.

Inappropriate replacement windows.

46. CORNICES

Cornices are important in providing decoration at the tops of buildings. Preserve, maintain, or repair original configuration and details of brick, sheet metal, or terra cotta cornices. Cornices should not be removed, concealed or covered with modern materials.

- A. Missing cornices should be replaced based upon physical or pictorial evidence. If no such evidence exists, a simple wood cornice in keeping with other cornices in the commercial area is appropriate.
- B. Cornices should not be added to buildings where no physical or pictorial evidence for such a cornice existed.

47. ROOFS

Most roofs on St. Elmo's commercial buildings are flat and are not readily visible from the street. Details such as parapet walls should be preserved, maintained, or repaired.

- A. Most commercial building roofs have flat or sloping roofs which are not visible from the street. If any metal roofs exist they should be preserved and maintained where feasible. However, if replacement is required, new roofs of rolled or asphalt roofing materials are appropriate.
- B. Parapet walls and features such as concrete or stone piers should not be altered or removed.

48. ARCHITECTURAL FEATURES

Original architectural and decorative features should be preserved, maintained, and repaired. These features may include cast iron pilasters, second floor porches, brick corbelling or inlaid patterns, terra cotta, decorative cast concrete, window hoods, and cornices. Architectural features should not be removed or concealed.

- A. Architectural features which have been removed should be replaced based upon their original design, materials, proportion, and details.
- B. Architectural features should not be added to a building where none originally existed.
- C. Architectural features should be repaired using compatible materials.
- D. Cast iron columns or pilasters on storefronts should be maintained through regular painting. If cleaning is desired, the use of abrasive cleaning methods such as sandblasting is less desirable than chemical or detergent cleaning.

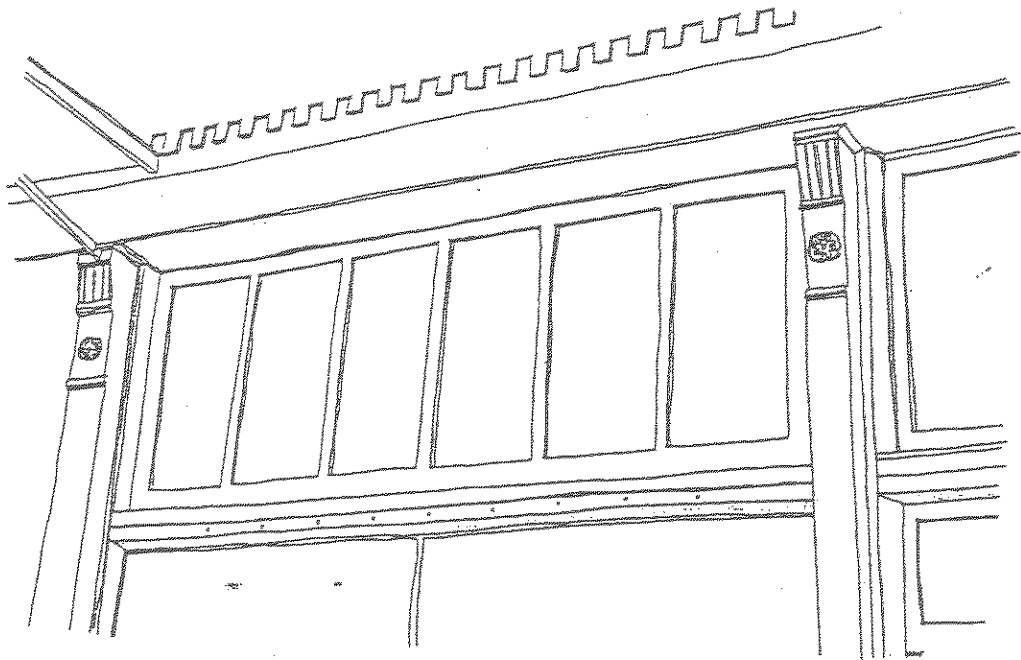

Original transoms and cast iron pilasters should be retained (3904 St. Elmo).

49. AWNINGS

Awnings were historically common for commercial buildings and the application of new awnings for St. Elmo's commercial buildings is appropriate.

- A. The addition of awnings to commercial buildings is appropriate. Awnings should be in traditional awning designs, materials, and placement.
- B. Storefronts and upper facade windows are both appropriate locations for awnings.
- C. Awnings may be retractable or fixed in place and should fit the opening to which they are applied. Shed awnings are appropriate for rectangular openings while arched awnings are appropriate for arched openings.
- D. Awning materials should be canvas, acrylic, or vinyl coated. The use of fixed metal, vinyl, or wood awnings is discouraged.
- E. Shed awnings are most appropriate for St. Elmo buildings. The use of bubble, concave, or convex forms is discouraged. Internally lit awnings are also less appropriate.
- F. Transom lights of prism glass or stained glass should not be covered by awnings.

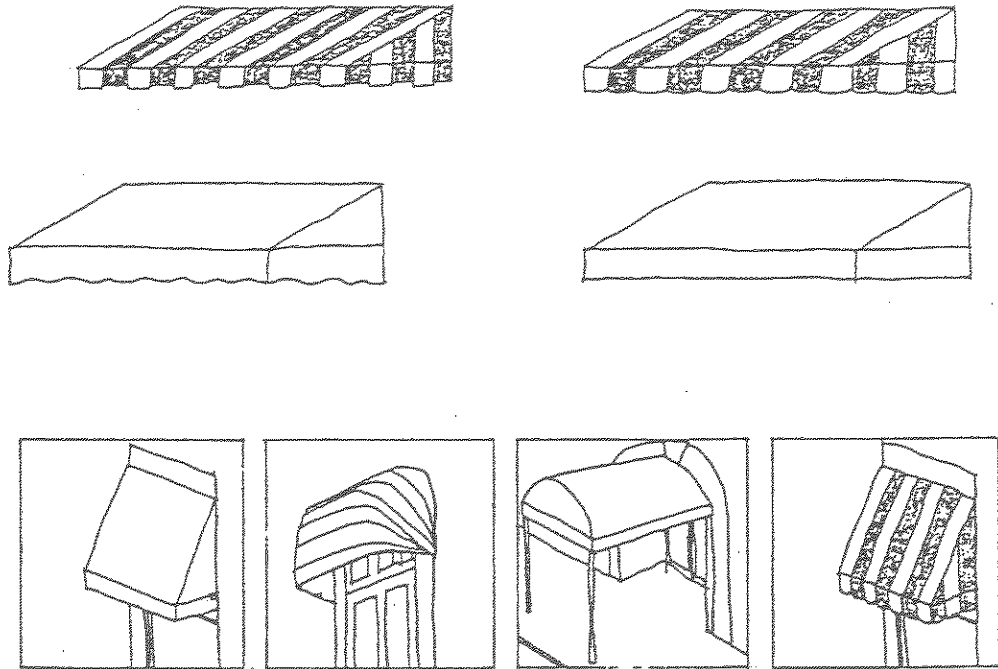

Appropriate commercial awnings.

50. LIGHTING

Light fixtures for commercial buildings should be as simple as possible and mounted where they will be partially or completely hidden. Any historic light fixtures should be preserved, maintained, and repaired.

- A. In the absence of historic light fixtures, use concealed up-lit light fixtures, fixtures of simple design, or fixtures appropriate to the period of the building.
- B. The use of "Colonial" coach lights and similar fixtures is discouraged.

Spotlights

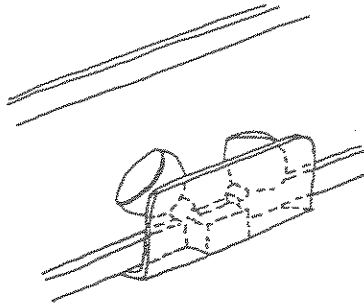

Gooseneck

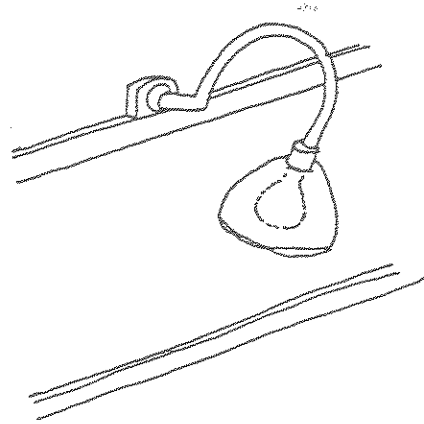

Fluorescent

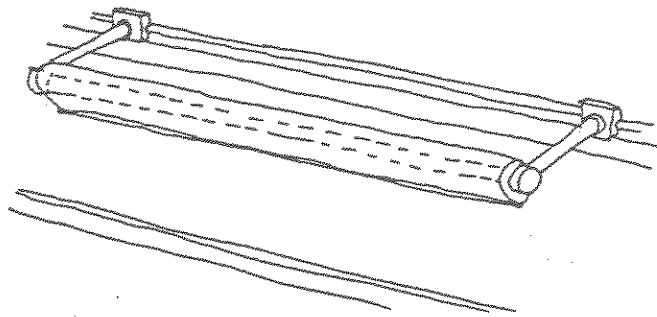

Appropriate commercial lighting fixtures.

51. SIGNS

Commercial buildings have traditionally had a variety of sign designs and placement and there should be wide flexibility for their use for St. Elmo's businesses.

- A. Historic signs should be preserved, maintained, and repaired.
- B. New signs should be of traditional materials such as wood, glass, copper or bronze letters. Sandblasted wood signs are appropriate. Plastic substrate signs, plywood signs, or unfinished wood are not recommended.
- C. Signs should be sized in proportion to the building. Avoid oversized signs.
- D. Buildings should have no more than three signs, not counting signs painted on windows.
- E. Signs which resemble logos or symbols for businesses are encouraged.
- F. Signs should have no more than two or three colors - colors should be coordinated with overall building colors.
- G. Serif, sans serif, or script lettering are traditional lettering styles for signs. Letters should not exceed 18 inches in height and cover more than 60% of the total sign area.
- H. Traditional sign locations include storefront beltcourses, upper facade walls (not to exceed 20% of the overall wall surface), hanging or mounted inside windows, or projecting from the face of the building.
- I. Mounting brackets and hardware for signs should be anchored into mortar not masonry.
- J. Avoid fake historic signs such as "Colonial" designs.
- H. Lighting for signs should be concealed. Spot or up-lit lighting for signs is recommended. Internally-lit signs are not appropriate for the downtown area.

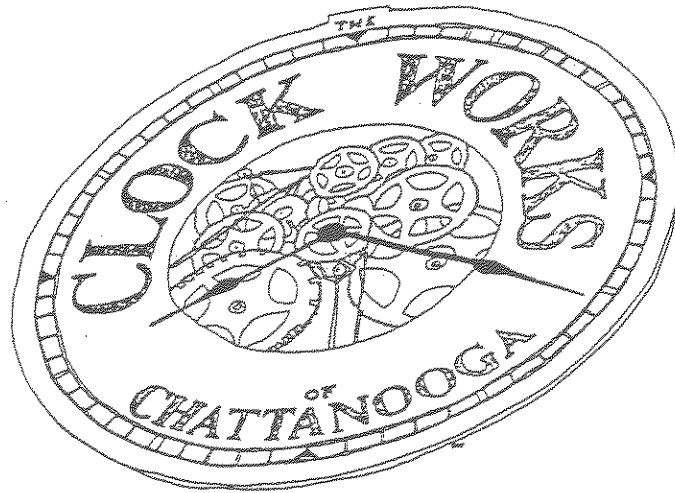

Appropriate logo sign at 3907 St. Elmo Avenue.



Appropriate projecting sign at 3905 St. Elmo Avenue.

52. ADDITIONS

Additions to commercial buildings are fine as long as they are located at the rear of the building or a side not readily visible from the street. Rooftop additions are less appropriate but if they are added they should be set back from the front of the building and not be readily visible from the street.

- A. Rooftop penthouses or additional stories should not be constructed unless the addition will not be readily visible from the street or other pedestrian viewpoints. Roof additions should be set back from the main facade.
- B. Additions at the rear of buildings are appropriate. Rear additions should be compatible with the original building in scale, proportion and rhythm of openings, and size.
- C. Rear additions should be of wood or brick construction. Metal or concrete additions are less desirable.
- D. Rear additions should be constructed to cause minimal damage or removal of original walls and details from the rear of the building.

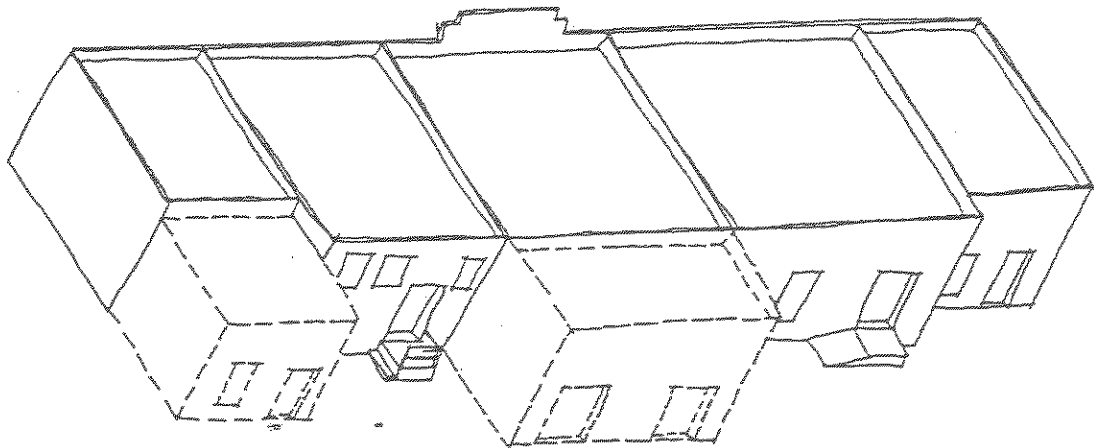

New additions should be located on the rear facades.

53. NEW COMMERCIAL BUILDINGS

New buildings in the St. Elmo commercial area should be representative of their period and be compatible with adjacent buildings in scale, height, materials, orientation, shape, placement, and rhythm and proportion of openings.

- A. New construction should be compatible in height with adjacent buildings. In St. Elmo one- to-two story buildings are most appropriate. New buildings should not exceed three-stories in height.
- B. Masonry (brick and stone) is the most appropriate material for new construction. Wood construction is also acceptable although less desirable.
- C. New buildings should be aligned with adjacent buildings along the street and conform to existing setbacks.
- D. New construction should be of similar width and scale and have similar proportions as adjacent buildings.
- E. New construction should be oriented towards the major street.
- F. New construction should have flat roof forms consistent with adjacent buildings.
- G. Window size and proportion of openings should be consistent with adjacent buildings.
- H. New buildings should maintain the traditional separation between storefronts and upper facades. This separation should be in alignment with adjacent buildings.
- I. New buildings which are constructed over several lots should have vertical divisions to maintain traditional building widths.
- J. Historic styles which pre-date St. Elmo such as Colonial Williamsburg designs are not appropriate.

APPENDICES

APPENDIX A - GUIDELINE CHART

APPENDIX B - SAMPLE COA APPLICATION

APPENDIX C - THE SECRETARY OF THE INTERIOR'S
STANDARDS FOR REHABILITATION

APPENDIX D - BASIC MAINTENANCE ADVICE

APPENDIX E - DEFINITIONS AND TERMS

APPENDIX F - BIBLIOGRAPHY

APPENDIX A - GUIDELINE CHART

TYPE OF WORK	NO APPROVAL REQUIRED	COA APPROVAL REQUIRED	BUILDING PERMIT REQUIRED
ADDITIONS		X	X
AWNINGS		X	X
BRICKWORK		X	X
DECKS		X	X
DEMOLITION		X	X
DOORS		X	
FENCES		X	
FIRE ESCAPES		X	X
GLASS (Replacement to match original)	X	X	
GLASS (Replacement not matching original)		X	
GLASS (Removal of historic glass)		X	
GUTTERS /DOWNSPOUTS		X	
HANDICAPPED RAMPS		X	X
LANDSCAPING	X* Except historic fences and retaining walls.		
LIGHT FIXTURES		X	
MASONRY (Cleaning/Repair)		X	

TYPE OF WORK	NO APPROVAL REQUIRED	COA REQUIRED	BUILDING PERMIT REQUIRED
MECHANICAL SYSTEMS		X	X
MOVING BUILDINGS		X	X
NEW BUILDINGS/ STRUCTURES		X	X
PAINT COLORS	X		
PARKING LOTS		X	X
PORCHES		X	X
RETAINING WALLS		X	
ROOFS		X	X
SCREENS		X	X
SHUTTERS		X	
SIDEWALKS		X	X
SIDING		X	X
SIGNS		X	X
SKYLIGHTS		X	
SOLAR COLLECTORS		X	X
STAIRCASES (Exterior)		X	X
STORM DOORS /WINDOWS		X	
WINDOWS		X	X

APPENDIX B - SAMPLE CERTIFICATE OF APPROPRIATENESS APPLICATION
(COA)

Application for Certificate of Appropriateness

Office Use Only

Application no. _____

Staff Approval _____

Date _____

CHZC Review _____

District _____

Property Address _____

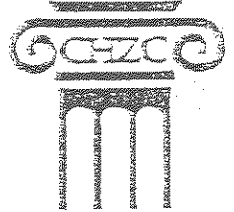

Chattanooga
Historic
Zoning
Commission

Type of Work (Check boxes that apply)

- 1) Exterior Alteration or Repair
- 2) New Construction
- Primary Structure
- Garage/Outbuilding
- New Addition
- Other
- 3) Demolition
- 4) Relocation

Applicant/Owner Information

Owners Name _____

Street Address _____

City _____ State _____ Zip _____

Day Phone _____ Home Phone _____ Fax _____

Name of Applicant (if different from owner) _____

Address _____

City _____ State _____ Zip _____

Day Phone _____ Home Phone _____ Fax _____

The undersigned does hereby declare that the statements contained in this document are true and correct to the best of his/her knowledge, information & belief.

Signature of OWNER _____ Date _____

Signature of APPLICANT _____ Date _____

Return application to: Planning & Design Studio, Development Resource Center, 1250 Market Street, Suite 3010, Chattanooga, TN 37402-2713. The Chattanooga Historic Zoning Commission meets on the 3rd Thursday of each month in the Planning & Design Studio (address above).

Applications must be submitted ten (10) working days prior to the meeting. Please call 423-668-2262 with any questions. Applications can be faxed to 432-668-2278.

Application for Certificate of Appropriateness

Page. 2

Project Description Form

Staff Use Only:

Application No. _____ Date _____

District _____

Property Address _____

Please describe in detail all work to be done for each item checked on the COA application form:

Signature _____ Date _____



APPENDIX C - THE SECRETARY OF THE INTERIOR'S STANDARDS FOR REHABILITATION

The Secretary of the Interior's Standards for Rehabilitation are standards used throughout the country as a basis for local design review guidelines. These standards are the basic points from which the St. Elmo guidelines have been developed.

The Standards that follow were originally published in 1977 and revised in 1990 as part of Department of the Interior regulations (36 CFR Part 67, Historic Preservation Certifications). They pertain to historic buildings of all materials, construction types, sizes, and occupancy and encompass the exterior and the interior of historic buildings. The Standards also encompass related landscape features and the building's site and environment as well as attached, adjacent or related new construction. The Standards are to be applied to specific, rehabilitation projects in a reasonable manner, taking into consideration economic and technical feasibility.

1. A property shall be used for its historic purpose or be placed in a new use that requires minimal change to the defining characteristics of the building and its site and environment.
2. The historic character of a property shall be retained and preserved. The removal of historic materials or alteration of features and spaces that characterize a property shall be avoided.
3. Each property shall be recognized as a physical record of its time, place, and use. Changes that create a false sense of historical development, such as adding conjectural features or architectural elements from other buildings, shall not be undertaken.
4. Most properties change over time; those changes that have acquired historic significance in their own right shall be retained and preserved.
5. Distinctive features, finishes, and construction techniques or examples of craftsmanship that characterize a property shall be preserved.
6. Deteriorated historic features shall be repaired rather than replaced. Where the severity of deterioration requires replacement of a distinctive feature, the new feature shall match the old in design, color, texture, and other visual qualities and, where possible, materials. Replacement of missing features shall be substantiated by documentary, physical, or pictorial evidence.
7. Chemical or physical treatments, such as sandblasting, that cause damage to historic materials shall not be used. The surface cleaning of structures, if appropriate, shall be undertaken in the gentlest means possible.
8. Significant archaeological resources affected by a project shall be protected and preserved. If such resources must be disturbed, mitigation measures shall be undertaken.
9. New additions, exterior alterations, or related new construction shall not destroy historic materials that characterize the property. The new work shall be differentiated from the old and shall be compatible with the massing, size, scale, and architectural features to protect the historic integrity of the property and its environment.
10. New additions and adjacent or related new construction shall be undertaken in such a manner that if removed in the future, the essential form and integrity of the historic property and its environment would be unimpaired.

APPENDIX D - BASIC MAINTENANCE ADVICE

MATERIALS

1. Prevent water from making contact with exterior wood siding. Of particular importance is keeping all gutters and downspouts in good repair to keep water from infiltrating the wood surface.
2. All exposed wood should be kept painted or treated with preservatives.
3. Repairs for wood siding such as cracks can be made through the use of waterproof glue or plastic wood. Large cracks may be filled with caulk followed by putty or plastic wood. The surface should then be sanded, allowed to dry, and painted.
4. Where exterior siding has to be replaced the use of pressure treated wood is recommended to prevent deterioration.
5. Oil based paints are recommended for exterior siding.
6. Keep exterior brick clean of mildew, efflorescence and dirt. Also keep exterior brick clean of vines, ivy, and other plant materials. Washing with detergents and water are best for exterior masonry and mortar. Sandblasting, waterblasting and other abrasive cleaning methods are detrimental to historic buildings and should not be used.
7. Repointing of historic mortar should be with a mortar which matches the original in appearance and composition. Most mortar from before 1900 was composed of lime and sand and a mortar with similar content should be applied. The use of Portland cement is generally not appropriate due to the hardness of the mortar versus the softness of the brick.
8. Most silicone based or waterproof coatings have limited effectiveness and may actually add to moisture problems by not allowing the brick to breathe. The use of these products is discouraged.

ROOFS, CORNICES, CHIMNEYS

1. Check the roof regularly for leaks, deterioration of flashing, and worn roof surfaces such as rolled or asphalt shingles. An inspection of the upper floor or attic space during or following a rainstorm can also assist in detection of water related problems.
2. Know what metals are used in your cornice or roof's flashing and use only similar metals during replacement or repair. Different metals should not touch each other or a galvanic reaction may occur leading to corrosion.
3. Metal roofs and cornices should be kept painted to prevent rust and deterioration. Appropriate paints include those with an iron oxide oil base. Asphalt based paints and aluminum paints should not be used on historic metals as they could accelerate the rusting process.
4. Chimneys should be regularly checked for cracking, leaning, spalling, and infestation by birds and insects. The use of chimney caps over chimneys or flue openings is recommended to keep out moisture.

GUTTERS AND DOWNSPOUTS

1. Keep gutters and downspouts in good repair. Make sure they are properly connected, are clean of leaves and other debris, and channel water effectively away from the building. Seal all cracks in downspouts with silicone caulk or sealants.
2. The use of splash blocks to keep water away from the foundation is recommended.
3. Gutters and downspouts which are deteriorated should be replaced with new gutters and downspouts. Half-round gutters and round downspouts are preferable to corrugated designs.

FOUNDATIONS

1. All water should drain away from a building and should not enter the foundation.
2. Trees, shrubs, and other plants should be kept well away from the foundation to prevent damage from moisture and root movement.

PORCHES AND EXTERIOR ORNAMENTATION

1. Use pressure treated wood for exterior repairs and replacement.
2. Keep all porch and trim elements painted.

ENTRANCES

1. Doors, transoms, and sidelights should be kept clean and the glass should be continually washed.
2. Original locks and hardware should be kept oiled and in good repair. If original hardware is missing or is deteriorated, the use of reproduction locks and hardware suitable for the building is recommended.
3. Doors with stained wood finish should be kept varnished and paint over the wood finish is not recommended.

WINDOWS

1. Windows should be kept clean and free of dirt and grime. Wood sash surfaces should be painted regularly.
2. Windows should be kept caulked and sealed to aid in energy conservation.
3. Shutters and blinds should be kept painted and in good repair.
4. Old or deteriorated curtains or shades behind windows should be removed or replaced.

AWNINGS

1. Canvas awnings should be washed periodically and kept in good repair.
2. Awning hardware should be regularly checked for rust or loose mechanisms.

3. Awnings which become torn or otherwise deteriorated should be replaced.

SIGNS

1. Abandoned signs and sign hardware should be removed from buildings, unless historic.
2. Signs should be kept painted and mounting bolts should be checked periodically to make sure they are secure.
3. Light fixtures, conduits, and wiring for signs should be inspected and replaced when necessary.

APPENDIX E - DEFINITIONS AND TERMS

A. Procedural Definitions

Certificate of Appropriateness: A document awarded by a preservation commission allowing an applicant to proceed with a proposed alteration, demolition, or new construction in a designated area or site, following a determination of the proposal's suitability according to applicable criteria.

Certified Local Government: Any city, county, parish, township, municipality, or borough or any other general purpose subdivision enacted by the National Preservation Act Amendments of 1980 to further delegate responsibilities and funding to the local level.

Due process: The established procedure by which legal action is carried out.

Normally Required: Mandatory actions, summarized in the guidelines, whose compliance is enforced by the preservation commission.

Public notice: The classified advertisement of an event, such as a preservation commission meeting, that is published in the local newspaper and posted in the city government building in order to notify the general public of the upcoming event.

Recommended: Suggested, but not mandatory actions summarized in the guidelines.

B. Technical Definitions

Adaptive Use: Rehabilitation of a historic structure for use other than its original use such as a residence converted into offices.

Addition: New construction added to an existing building or structure.

Alteration: Work which impacts any exterior architectural feature including construction, reconstruction, repair, or removal of any building element.

Appropriate: Especially suitable or compatible.

Building: A structure used to house human activity such as a dwelling or garage.

Character: The qualities and attributes of any structure, site, street or district.

Commission: The Chattanooga Historic Zoning Commission.

Configuration: The arrangement of elements and details on a building or structure which help to define its character.

Contemporary: Reflecting characteristics of the current period. Contemporary denotes characteristics which illustrate that a building, structure, or detail was constructed in the present or recent past rather than being imitative or reflective of a historic design.

Compatible: In harmony with location and surroundings.

Context: The setting in which a historic element, site, structure, street, or district exists.

Demolition: Any act which destroys in whole or in part a building or structure.

Demolition by Neglect: The destruction of a building or structure through abandonment or lack of maintenance.

Design Guidelines: Criteria developed by preservation commissions to identify design concerns in an area and to help property owners ensure that rehabilitation and new construction respect the character of designated buildings and districts.

Element: A material part or detail of a site, structure, street, or district.

Elevation: Any one of the external faces or facades of a building.

Fabric: The physical material of a building, structure, or community, connoting an interweaving of component parts.

Facade: Any one of the external faces or elevations of a building.

Harmony: Pleasing or congruent arrangement.

Height: The distance from the bottom to the top of a building or structure.

Historic District: A geographically definable area with a significant concentration of buildings, structures, sites, spaces, or objects unified by past events, physical development, design, setting, materials, workmanship, sense of cohesiveness or related historical and aesthetic associations. The significance of a district may be recognized through listing in a local, state, or national landmarks register and may be protected legally through enactment of a local historic district ordinance administered by a historic district board or commission.

Historic Imitation: New construction or rehabilitation where elements or components mimic an architectural style but are not of the same historic period as the existing buildings (historic replica).

Infill: New construction in historic districts on vacant lots or to replace existing buildings.

Landmark: A building, structure, object or site which is identified as a historic resource of particular significance.

Landscape: The totality of the built or human-influenced habitat experienced at any one place. Dominant features are topography, plant cover, buildings, or other structures and their patterns.

Maintain: To keep in an existing state of preservation or repair.

Material Change: A change that will affect either the exterior architectural or environmental features of an historic property or any structure, site, or work of art within an historic district.

New construction: Construction which is characterized by the introduction of new elements, sites, buildings, or structures or additions to existing buildings and structures in historic areas and districts.

Obscured: Covered, concealed, or hidden from view.

Preservation: Generally, saving from destruction or deterioration old and historic buildings, sites, structures, and objects and providing for their continued use by means of restoration, rehabilitation, or adaptive use.

Proportion: Harmonious relation of parts to one another or to the whole.

Recommendation: An action or activity advised but not required by the Chattanooga Historic Zoning Commission.

Reconstruction: The act or process of reproducing by new construction the exact form and detail of a vanished building, structure, or object, or a part thereof, as it appeared at a specific period of time.

Rehabilitation: The act or process of returning a property or building to usable condition through repair, alteration, and/or preservation of its features which are significant to its historical, architectural, and cultural values.

Restoration: The act or process of accurately taking a building's appearance back to a specific period of time by removing later work and by replacing missing earlier features to match the original.

Retain: To keep secure and intact. In the guidelines, "retain" and "maintain" describe the act of keeping an element, detail, or structure and continuing the same level of repair to aid in the preservation of elements, sites and structures.

Re-use: To use again. An element, detail, or structure might be reused in historic districts.

Rhythm: Movement or fluctuation marked by the regular occurrence or natural flow of related elements.

Scale: Proportional elements that demonstrate the size, materials, and style of buildings.

Setting: The sum of attributes of a locality, neighborhood, or property that defines its character.

Significant: Having particularly important associations within the contexts of architecture, history, and culture.

Stabilization: The act or process of applying measures essential to the maintenance of a deteriorated building as it exists at present, establishing structural stability and a weather-resistant enclosure.

Streetscape: The distinguishing character of a particular street as created by its width, degree of curvature, paving materials, design of the street furniture, and forms of surrounding buildings.

Style: A type of architecture distinguished by special characteristics of structure and ornament and often related in time; also a general quality of a distinctive character.

C. GLOSSARY OF TERMS

Addition New construction added to an existing building or structure.

Alteration Work which impacts any exterior architectural feature including construction, reconstruction, or removal of any building or building element.

American bond A brickwork pattern where most courses are laid flat, with the long "stretcher" edge exposed, but every fifth to eighth course is laid perpendicularly with the small "header" end exposed, to structurally tie the wall together.

Apron A decorative, horizontal trim piece on the lower portion of an architectural element.

Arch A curved construction of wedge-shaped stones or bricks which spans an opening and supports the weight above it. (see flat arch, jack arch, segmental arch and semi-circular arch)

Attic The upper level of a building, not of full ceiling height, directly beneath the roof.

Baluster One of a series of short, vertical, often vase-shaped members used to support a stair or porch handrail, forming a balustrade.

Balustrade An entire rail system with top rail and balusters.

Bargeboard A board which hangs from the projecting end of a gable roof, covering the end rafters, and often sawn into a decorative pattern.

Bay The portion of a facade between columns or piers providing regular divisions and usually marked by windows.

Bay window A projecting window that forms an extension to the floor space of the internal rooms; usually extends to the ground level.

Belt course A horizontal band usually marking the floor levels on the exterior facade of a building.

Board and batten Siding fashioned of boards set vertically and covered where their edges join by narrow strips called battens.

Bond A term used to describe the various patterns in which brick (or stone) is laid, such as "common bond" or "Flemish bond."

Bracket A projecting element of wood, stone or metal which spans between horizontal and vertical surfaces (eaves, shelves, overhangs) as decorative support.

Bulkhead The structural panels just below display windows on storefronts. Bulkheads can be both supportive and decorative in design. 19th century bulkheads are often of wood construction with rectangular raised panels. 20th century bulkheads may be of wood, brick, tile, or marble construction. Bulkheads are also referred to as kickplates.

Bungalow Common house form of the early twentieth century distinguished by horizontal emphasis, wide eaves, large porches and multi-light doors and windows.

Capital The head of a column or pilaster.

Casement window A window with one or two sashes which are hinged at the sides and usually open outward.

Certified Local Government Any city, county, parish, township, municipality, or borough or any other general purpose subdivision enacted by the National Preservation Act Amendments of 1980 to further delegate responsibilities and funding to the local level.

Clapboards Horizontal wooden boards, thinner at the top edge, which are overlapped to provide a weather-proof exterior wall surface.

Classical order Derived from Greek and Roman architecture, a column with its base, shaft, capital and entablature having standardized details and proportions, according to one of the five canonized modes: Doric, Tuscan, Ionic, Corinthian, or Composite.

Clipped gable A gable roof where the ends of the ridge are terminated in a small, diagonal roof surface.

Colonial Revival House style of the early twentieth century based on interpretations of architectural forms of the American colonies prior to the Revolution.

Column A circular or square vertical structural member.

Corbel In masonry, a projection, or one of a series of projections, each stepped progressively farther forward with height and articulating a cornice or supporting an overhanging member.

Corinthian order Most ornate classical order characterized by a capital with ornamental acanthus leaves and curled fern shoots.

Cornice The uppermost, projecting part of an entablature, or feature resembling it. Any projecting ornamental molding along the top of a wall, building, etc.

Cresting A decorated ornamental finish along the top of a wall or roof, often made of ornamental metal.

Cross-gable A secondary gable roof which meets the primary roof at right angles.

Dentils A row of small tooth-like blocks in a classical cornice.

Doric order A classical order with simple, unadorned capitals, and with no base.

Dormer window A window that projects from a roof.

Double-hung window A window with two sashes, one sliding vertically over the other.

Eave The edge of a roof that projects beyond the face of a wall.

Elevation Any of the external faces of a building.

Ell The rear wing of a house, generally one room wide and running perpendicular to the principal building.

Engaged column A round column attached to a wall.

Entablature A part of a building of classical order resting on the column capital; consists of an architrave, frieze, and cornice.

Facade The face or front elevation of a building.

Fanlight A semi-circular window usually over a door with radiating muntins suggesting a fan.

Fascia A projecting flat horizontal member or molding; forms the trim of a flat roof or a pitched roof; also part of a classical entablature.

Fenestration The arrangement of windows on a building.

Finial A projecting decorative element, usually of metal, at the top of a roof turret or gable.

Fishscale shingles A decorative pattern of wall shingles composed of staggered horizontal rows of wooden shingles with half-round ends.

Flashing Thin metal sheets used to prevent moisture infiltration at joints of roof planes and between the roof and vertical surfaces.

Flat arch An arch whose wedge-shaped stones or bricks are set in a straight line; also called a jack arch.

Flemish bond A brick-work pattern where the long "stretcher" edge of the brick is alternated with the small "header" end for decorative as well as structural effectiveness.

Fluting Shallow, concave grooves running vertically on the shaft of a column, pilaster, or other surface.

Foundation The lowest exposed portion of the building wall, which supports the structure above.

Frieze The middle portion of a classical cornice; also applied decorative elements on an entablature or parapet wall.

Gable The triangular section of a wall to carry a pitched roof.

Gable roof A pitched roof with one downward slope on either side of a central, horizontal ridge.

Gambrel roof A ridged roof with two slopes on either side.

Ghosts Outlines or profiles of missing buildings or building details. These outlines may be visible through stains, paint, weathering, or other residue on a building's facade.

Greek Revival style Mid-nineteenth century revival of forms and ornament of architecture of ancient Greece.

Hipped roof A roof with uniform slopes on all sides.

Hood molding A projecting molding above an arch, doorway, or window, originally designed to direct water away from the opening; also called a drip mold.

Ionic order One of the five classical orders used to describe decorative scroll capitals.

Infill New construction where there had been an opening before, such as a new building between two older structures; or block infill between porch piers or in an original window opening.

Jack arch (see Flat arch)

Keystone The wedge-shaped top or center member of an arch.

Knee brace An oversize bracket supporting a cantilevered or projecting element.

Lattice An openwork grill of interlacing wood strips used as screening.

Lintel The horizontal top member of a window, door, or other opening.

Mansard roof A roof with a double slope on all four sides, with the lower slope being almost vertical and the upper almost horizontal.

Masonry Exterior wall construction of brick, stone or adobe laid up in small units.

Massing The three-dimensional form of a building.

Metal standing seam roof A roof composed of overlapping sections of metal such as copper-bearing steel or iron coated with aterne alloy of lead and tin. These roofs were attached or crimped together in various raised seams for which the roof are named.

Modillion A horizontal bracket, often in the form of a plain block, ornamenting, or sometimes supporting, the underside of a cornice.

Mortar A mixture of sand, lime, cement, and water used as a binding agent in masonry construction.

Mullion A heavy vertical divider between windows or doors.

Multi-light window A window sash composed of more than one pane of glass.

Muntin A secondary framing member to divide and hold the panes of glass in multi-light window or glazed door.

Neo-classical Revival style Early twentieth century style which combines features of ancient, Renaissance, and Colonial architecture; characterized by imposing buildings with large columned porches.

Oriel window A bay window which emerges above the ground floor level.

Paired columns Two columns supported by one pier, as on a porch.

Palladian window A window with three openings, the central one arched and wider than the flanking ones.

Panelled door A door composed of solid panels (either raised or recessed) held within a framework of rails and stiles.

Parapet A low horizontal wall at the edge of a roof.

Pediment A triangular crowning element forming the gable of a roof; any similar triangular element used over windows, doors, etc.

Pier A vertical structural element, square or rectangular in cross-section.

Pilaster A square pillar attached, but projecting from a wall, resembling a classical column.

Pitch The degree of the slope of a roof.

Portico A roofed space, open or partly enclosed, forming the entrance and centerpiece of the facade of a building, often with columns and a pediment.

Portland cement A strong, inflexible hydraulic cement used to bind mortar. Mortar or patching materials with a high Portland cement content should not be used on old buildings. The Portland cement is harder than the masonry, thereby causing serious damage over annual freeze-thaw cycles.)

Preservation The act of maintaining the form and character of a building as it presently exists. Preservation stops deterioration and stabilizes the structure.

Pressed tin Decorative and functional metalwork made of molded tin used to sheath roofs, bays, and cornices.

Pyramidal roof A roof with four identical sides rising to a central peak.

Queen Anne style Popular late nineteenth century revival style of early eighteenth-century English architecture, characterized by irregularity of plan and massing and a variety of texture.

Quoins A series of stone, bricks, or wood panels ornamenting the outside of a wall.

Reconstruction The accurate recreation of a vanished, or irreplaceably damaged structure, or part thereof; the new construction recreates the building's exact form and detail as they appeared at some point in history.

Rehabilitation The act of returning a building to usable condition through repair, alteration, and/or preservation of its features.

Restoration The process of accurately taking a building's appearance back to a specific period of time by removing later work and by replacing missing earlier features to match the original.

Ridge The top horizontal member of a roof where the sloping surfaces meet.

Rusticated Roughening of stonework or concrete blocks to give greater articulation to each block.

Sash The moveable framework containing the glass in a window.

Segmental arch An arch whose profile or radius is less than a semicircle.

Semi-circular arch An arch whose profile or radius is a half-circle the diameter of which equals the opening width.

Sheathing An exterior covering of boards or other surface applied to the frame of the structure. (see Siding)

Shed roof A gently-pitched, almost flat roof with only one slope.

Sidelight a vertical area of fixed glass on either side of a door or window.

Siding the exterior wall covering or sheathing of a structure.

Sill The bottom crosspiece of a window frame.

Spindles Slender, elaborately turned wood dowels or rods often used in screens and porch trim.

Stabilization The essential maintenance of a deteriorated building as it exists at present, establishing structural stability and a weather-resistant enclosure.

Streetscape The over facade, not of a single structure, but of the many buildings which define the street.

Stretcher bond A brickwork pattern where courses are laid flat with the long "stretcher" edge exposed.

Surround An encircling border or decorative frame, usually at windows or doors.

Swag Carved ornament on the form of a cloth draped over supports, or in the form of a garland of fruits and flowers.

Transom A horizontal opening (or bar) over a door or window. (see Overlight)

Trim The decorative framing of openings and other features on a facade.

Turret A small slender tower.

Veranda A covered porch or balcony on a building's exterior.

Vergeboard The vertical face board following and set under the roof edge of a gable; sometimes decorated by carving.

Vernacular A regional form or adaptation of an architectural style.

Wall dormer Dormer created by the upward extension of a wall and a breaking of the roofline.

Water table A projecting horizontal ledge, intended to prevent water from running down the face of a wall's lower section.

Weatherboard Wood siding consisting of overlapping boards usually thicker at one edge than the other.

APPENDIX F - SUGGESTED BIBLIOGRAPHY

- Blumenson, John J.-G., Identifying American Architecture. Nashville: American Association for State and Local History, 1981.
- Evers, Christopher. The Old-House Doctor. Woodstock, New York: The Overlook Press, 1986.
- Douthat, James; Harris, Judy; and Pope, Frankie W. The St. Elmo Story. Chattanooga: St. Elmo Improvement League, 1986.
- Friedland, Edward P. Antique Houses: Their Construction and Restoration. Garden City, New York: Doubleday, 1981.
- Hanson, Shirley, and Nancy Hubby. Preserving and Maintaining the Older Home. New York: McGraw-Hill, 1983.
- Hutchins, Nigel. Restoring Old Houses. New York: Van Nostrand Reinhold, 1980.
- Kangas, Robert. The Old-House Rescue Book. Reston, Virginia: Reston Publishing Company, 1982.
- Labine, Clem, ed. Clem Labine's Traditional Building. Brooklyn, New York: Historical Trends Corporation.
- Litchfield, Michael W. Renovation: A Complete Guide. New York: Wiley, 1982.
- Livingood, James W. Hamilton County. Memphis: Memphis State University Press, 1981.
- McAlester, Virginia and Lee McAlester. A Field Guide to American Houses. New York: Alfred A. Knopf, 1984.
- Morton, W. Brown, III, Gary L. Hume, and Kay D. Weeks. The Secretary of the Interior's Standards for Rehabilitation and Guidelines for Rehabilitating Historic Buildings. 1979. Rev. ed. Washington, D.C.: Technical Preservation Services. U.S. Department of the Interior, 1990.
- Moss, Roger. Century of Color. Watkins Glen, N.Y.: The American Life Foundation, 1981.
- Nash, George. Old-houses. A Rebuilder's Manual. Englewood Cliffs, N.J.: Prentiss-Hall, 1980.

- Old-House Journal. Monthly. Old-House Journal Corporation, 435 Ninth Street, Brooklyn, New York, 11215.
- Park, Sharon D., AIA. The Use of Substitute Materials on Historic Building Exteriors. Preservation Brief no. 16. Washington, D.C.: Technical Preservation Services, U.S. Department of the Interior, 1989.
- Phillips, Steven J. Old-House Dictionary. Lakewood, Colorado: American Source Books, 1989.
- Rooney, William F. Practical Guide to Home Restoration. New York: Bantam/Hudson Idea Books, 1980.
- Rusk, Katherine. Renovating the Victorian House: A guide for Aficionados of Old Houses. San Francisco: One Hundred One Productions, 1981.
- Rypkema, Donovan D. The Economics of Historic Preservation. Washington: The National Trust for Historic Preservation, 1994.
- Schweitzer, Robert, and Michael W.R. Davis. America's Favorite Homes - Mail Order Catalogues As A Guide To Popular Early 20th Century Houses. Detroit: Wayne State University Press, 1990.
- Stahl, Frederick A. A Guide to the Maintenance, Repair, and Alteration of Historic Buildings. New York: Van Nostrand Reinhold, 1984.
- Stephen, George. New Life for Old Houses. Washington, D.C.: The Preservation Press, 1989.
- Technical Preservation Services, National Park Service, U.S. Department of the Interior. Respectful Rehabilitation. Washington, D.C.: The Preservation Press, 1982.
- _____. Preservation Briefs. Published periodically. Washington, D.C.: Government Printing Office.
- Weeks, Kay D. New Exterior Additions to Historic Buildings: Preservation Concerns. Preservation Brief no. 14. Washington, D.C.: Technical Preservation Services, U.S. Department of the Interior, 1986.
- Wilson, John. Chattanooga's Story. Chattanooga: Chattanooga Free-Press, 1980.
- Wilson, John. Scenic Historic Lookout Mountain. Chattanooga: Chattanooga Free-Press, 1977.